



## Rich's lesson module checklist

- Slides and labs 7 and X2 posted
- WB converted from PowerPoint
- Print out agenda slide and annotate page numbers
  
- Flash cards
- Page numbers
- 1<sup>st</sup> minute quiz
- Web Calendar summary
- Web book pages
- Commands
  
- Lock turnin directory at midnight
- Lab 7 tested
- Lab X2 tested
  
- 9V backup battery for microphone
- Backup slides, CCC info, handouts on flash drive
- Key card for classroom door



### **Student Learner Outcomes**

1. Navigate and manage the UNIX/Linux file system by viewing, copying, moving, renaming, creating, and removing files and directories.
2. Use the UNIX features of file redirection and pipelines to control the flow of data to and from various commands.
3. With the aid of online manual pages, execute UNIX system commands from either a keyboard or a shell script using correct command syntax.

## Introductions and Credits



Jim Griffin

- Created this Linux course
- Created Opus and the CIS VLab
- Jim's site: <http://cabrillo.edu/~jgriffin/>



Rich Simms

- HP Alumnus
- Started teaching this course in 2008 when Jim went on sabbatical
- Rich's site: <http://simms-teach.com>

And thanks to:

- John Govsky for many teaching best practices: e.g. the First Minute quizzes, the online forum, and the point grading system (<http://teacherjohn.com/>)



## Student checklist for attending class

The screenshot shows a web browser window with the URL [simms-teach.com/cis90calendar.php](http://simms-teach.com/cis90calendar.php). The page title is "Rich's Cabrillo College CIS Classes CIS 90 Calendar". The main content area is titled "CIS 90 (Fall 2014) Calendar" and includes a "Calendar" link. A table lists lessons, with Lesson 8 highlighted. The details for Lesson 8 are as follows:

Lesson	Date	Topics	Link
8	9/2	<p><b>Class and Linux Operations</b></p> <ul style="list-style-type: none"> <li>Understand how the course will work</li> <li>High-level overview of computers, operating systems and virtual machines</li> <li>Overview of UNIX/Linux market and architecture</li> <li>Using SSH for remote network logs</li> <li>Using terminals and the command line</li> </ul> <p><b>Materials</b></p> <p><a href="#">Presentation slides (download)</a></p> <p><b>Supplemental</b></p> <ul style="list-style-type: none"> <li>PowerPoint: Logging into Opus (download)</li> </ul> <p><b>Assignments</b></p> <ul style="list-style-type: none"> <li>Student Survey</li> <li>Lab 1</li> </ul> <p><b>CIS 90 Extras</b></p> <p><a href="#">Enter virtual classroom</a></p>	<p>2.4</p> <p>9/2-3</p> <p>9/2-4</p> <p>(high)</p>

1. Browse to:  
**<http://simms-teach.com>**
2. Click the **CIS 90** link.
3. Click the **Calendar** link.
4. Locate today's lesson.
5. Find the **Presentation slides** for the lesson and **download** for easier viewing.
6. Click the **Enter virtual classroom** link to join CCC Confer.
7. Log into Opus with Putty or ssh command.

Note: Blackboard Collaborate Launcher only needs to be installed once. It has already been downloaded and installed on the classroom PC's.



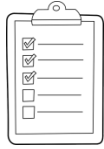

## Student checklist for suggested screen layout

Google

CCC Confer

Downloaded PDF of Lesson Slides

The screenshot displays a virtual classroom interface. On the left is a sidebar with navigation options like 'Login', 'Flashcards', and 'Admin'. The main area shows a 'Rich's Cabrillo College CIS 90 Calendar' with a table of lessons. Overlaid on this is a 'CCC Confer' window with a video feed of 'Rich Simms' and a list of participants. A 'Google' window shows a map of the San Francisco Bay Area. In the top right, an 'Adobe Acrobat Pro' window displays 'The CIS 90 System Playground' slide. In the bottom right, a terminal window shows a login prompt for 'Opus' with a password field and a 'Welcome to Opus' message.

CIS 90 website Calendar page

One or more login sessions to Opus



# Student checklist for sharing desktop with classmates

1) Instructor gives you sharing privileges

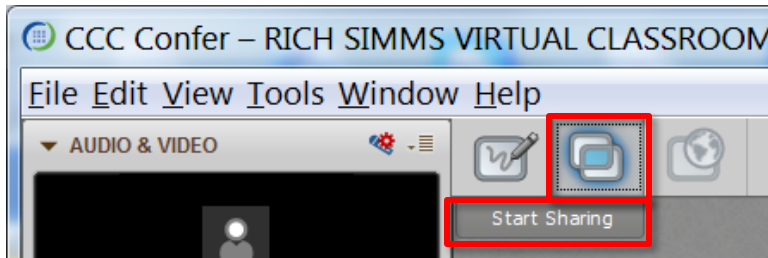

2) Click overlapping rectangles icon. If white "Start Sharing" text is present then click it as well.

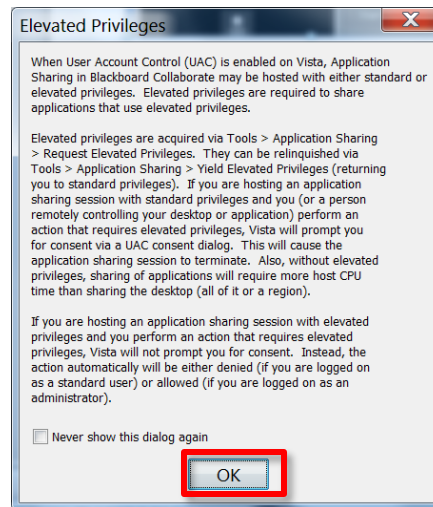

3) Click OK button.

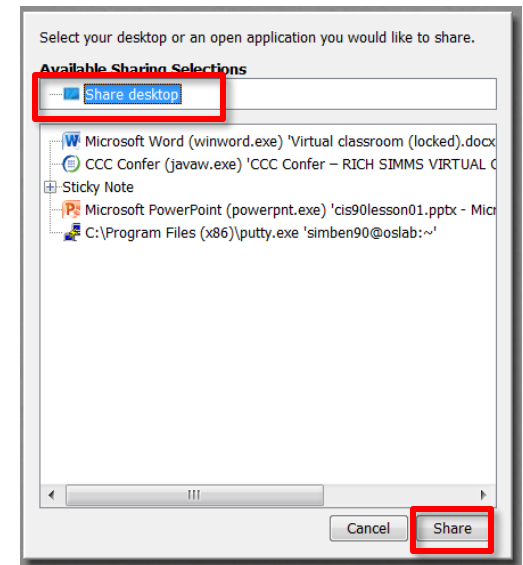

4) Select "Share desktop" and click Share button.

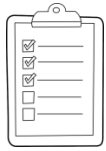

# Rich's CCC Confer checklist - setup



[ ] Preload White Board

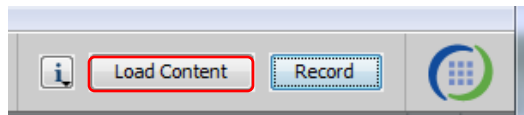

[ ] Connect session to Teleconference

*Session now connected to teleconference*

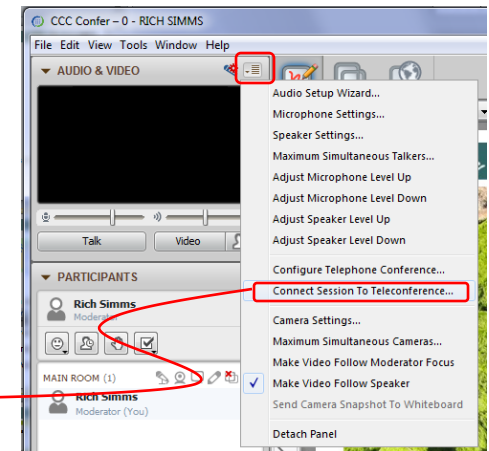
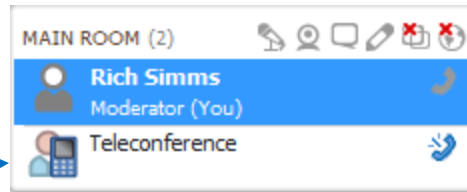

[ ] Is recording on?

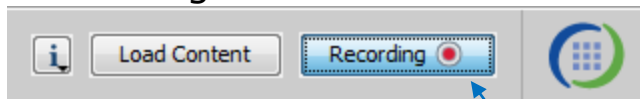

*Red dot means recording*

[ ] Use teleconferencing, not mic

*Should be grayed out*

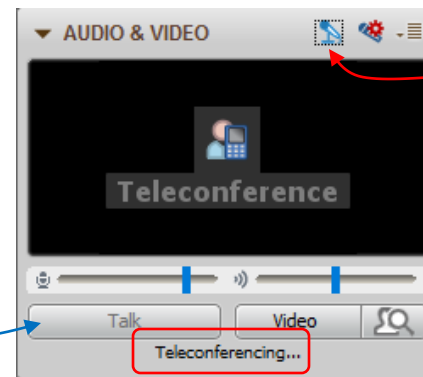

*Should change from phone handset icon to little Microphone icon and the Teleconferencing... message displayed*



## Rich's CCC Confer checklist - screen layout



The screenshot displays a Windows desktop with several applications open. On the left is the CCC Confer window, showing a video feed of Rich Simms and a list of participants. In the center is a Chrome browser window displaying a PDF document titled 'cis90-TEST-1-Fall-12.pdf'. Overlaid on the PDF is a terminal window (Putty) showing a login session for 'simben90@oslab'. To the right is the vSphere Client window, showing the vCenter interface for 'CIS 192'. Red callout boxes with white text identify the applications: 'foxit for slides' points to the PDF viewer, 'chrome' points to the browser, 'putty' points to the terminal, and 'vSphere Client' points to the vCenter interface.

[ ] layout and share apps







# Rich's CCC Confer checklist - webcam setup

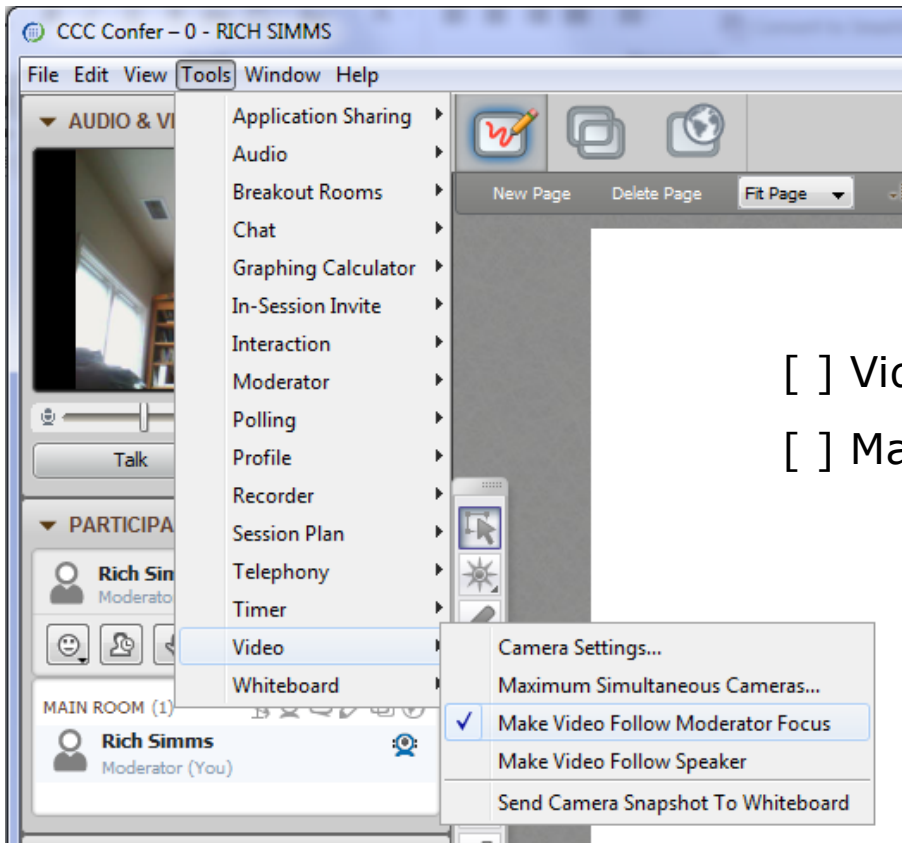

[ ] Video (webcam)

[ ] Make Video Follow Moderator Focus



# Rich's CCC Confer checklist - Elmo

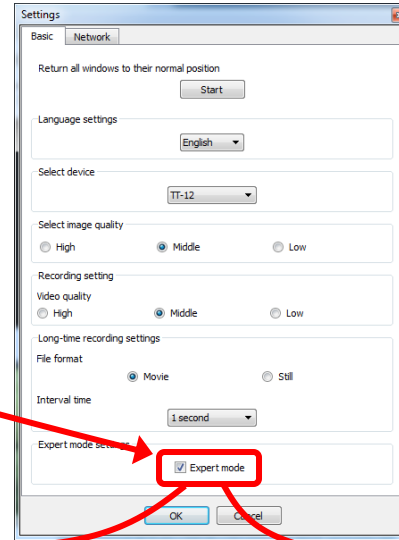
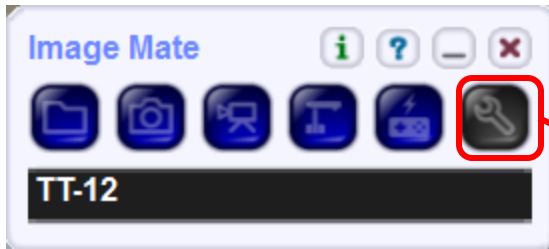

The "rotate image" button is necessary if you use both the side table and the white board.

Quite interesting that they consider you to be an "expert" in order to use this button!

Elmo rotated down to view side table



Elmo rotated up to view white board

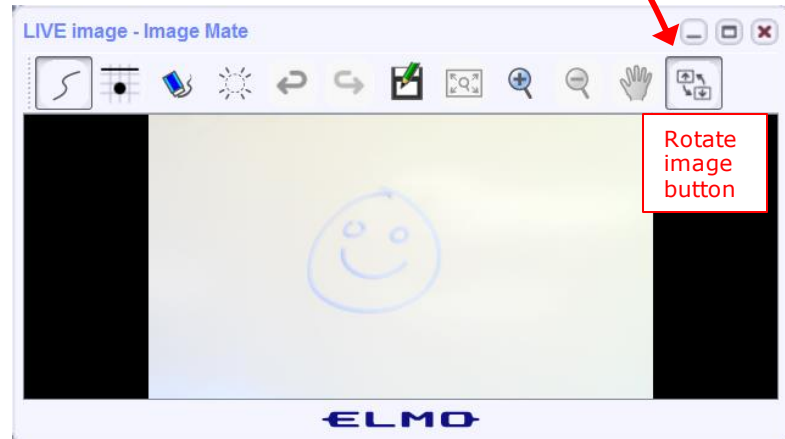

Run and share the Image Mate program just as you would any other app with CCC Confer

## Rich's CCC Confer checklist - universal fixes

Universal Fix for CCC Confer:

- 1) Shrink (500 MB) and delete Java cache
- 2) Uninstall and reinstall latest Java runtime
- 3) <http://www.cccconfer.org/support/technicalSupport.aspx>

Control Panel (small icons)



General Tab > Settings...

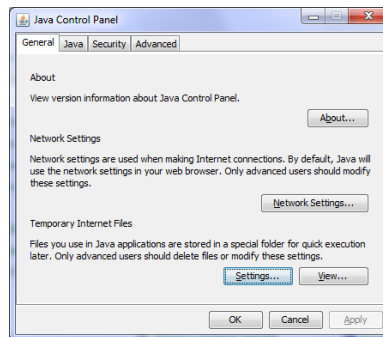

500MB cache size

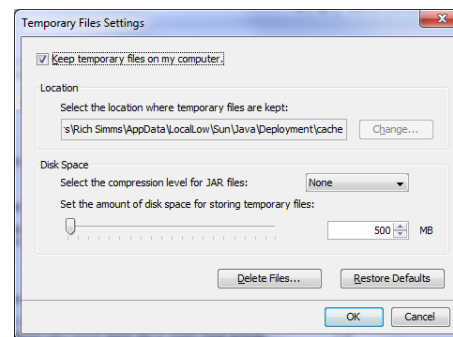

Delete these

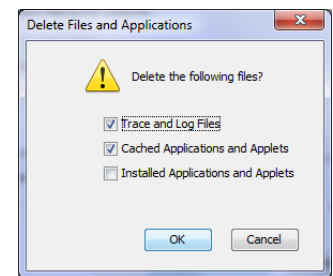

Google Java download





# Start



# Sound Check

*Students that dial-in should mute their line using \*6 to prevent unintended noises distracting the web conference.*

*Instructor can use  
\*96 to mute all student lines.  
\*5 to boost volume*



Instructor: **Rich Simms**

Dial-in: **888-886-3951**

Passcode: **136690**



Victoria



Oscar G.



Jesselle



Alex



Mitchel



Colin



Izzy

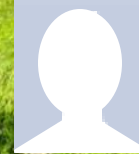

Luis C.



Cameron



Brandon



Dillon



Joseph



Steve

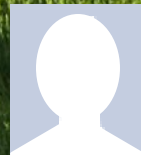

Bruno



Joshua



Vance



Adrian



Raul



Matt



Mike



Rodney



Sam



Kevin

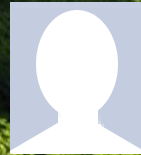

Allen



Zane



Diego

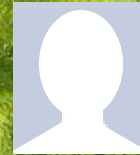

Dustin



Martin

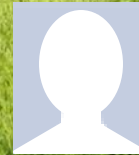

Zack



Ted



Eriberto

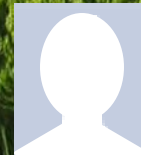

Dylan

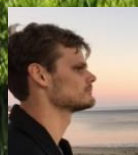

Kyle



Nestor

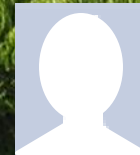

Oscar N.

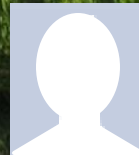

Ian

## First Minute Quiz

Please answer these questions **in the order** shown:

Use CCC Confer White Board

**email answers to: [risimms@cabrillo.edu](mailto:risimms@cabrillo.edu)**

**(answers must be emailed within the first few minutes of class for credit)** 15

# Input/Output Processing

## Objectives

- Identify the three open file descriptors an executing program is given when started.
- Be able to redirect input from files and output to files
- Define the terms pipe, filter, and tee
- Use pipes and tees to combine multiple commands
- Know how to use the following useful UNIX commands:
  - ❖ find
  - ❖ grep
  - ❖ wc
  - ❖ sort
  - ❖ spell

## Agenda

- Quiz
- Questions
- Warmup
- umask continued
- Housekeeping
- New commands (sort)
- Pretend you are a command (imagination)
- Sort command deep dive (good arg, no args, bad arg)
- Bringing it home (reality)
- File redirection
- The bit bucket
- Pipelines
- find command
- Filter commands (grep, spell, tee, cut)
- Pipeline practice
- Permissions, the rest of the story
- Assignment
- Wrap up





# Questions

# Questions?

Lesson material?

Labs? Tests?

How this course works?

- Graded work in home directories
- Answers in /home/cis90/answers

*Who questions much, shall learn much, and retain much.*

- Francis Bacon

*If you don't ask, you don't get.*

- Mahatma Gandhi

Chinese  
Proverb

他問一個問題，五分鐘是個傻子，他不問一個問題仍然是一個傻瓜永遠。

*He who asks a question is a fool for five minutes; he who does not ask a question remains a fool forever.*



# Warmup

File Tree Pathname Practice

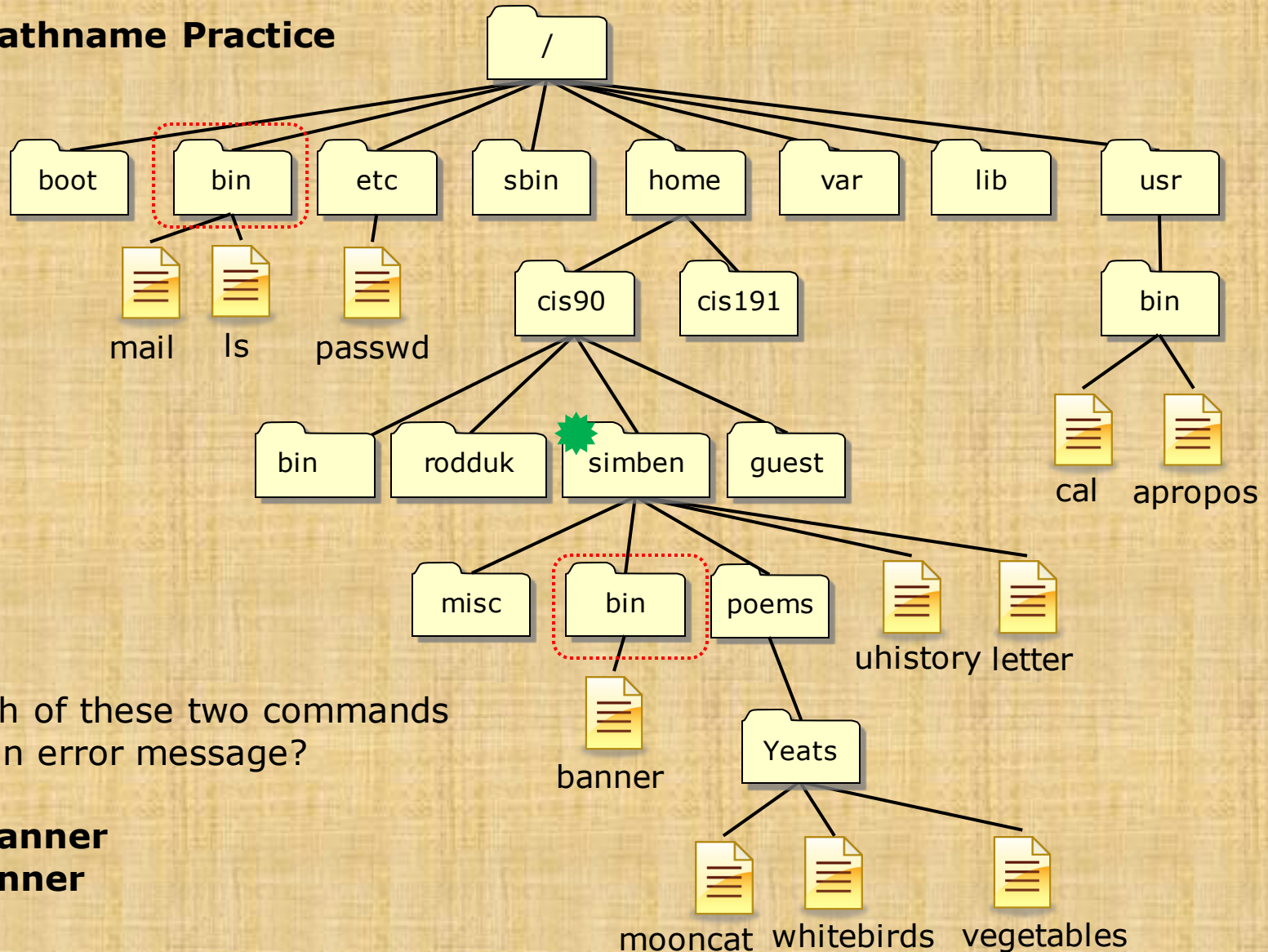



From  which of these two commands will generate an error message?

**touch /bin/banner**  
**touch bin/banner**

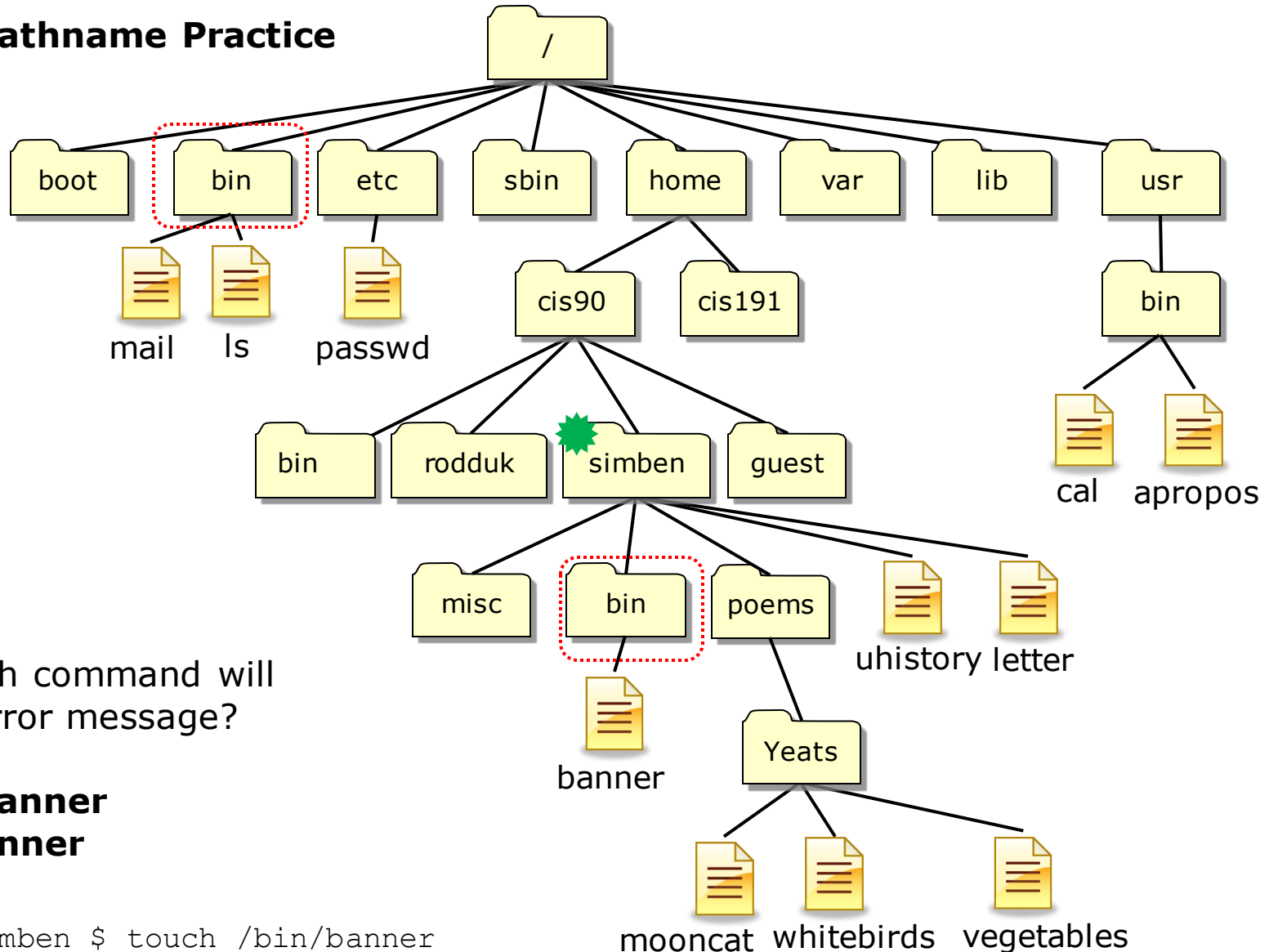

## File Tree Pathname Practice



From  which command will generate an error message?

**touch /bin/banner**  
**touch bin/banner**

```
/home/cis90/simben $ touch /bin/banner
touch: cannot touch `/bin/banner': Permission denied
```

*banner is in your local bin directory*

File Tree Pathname Practice

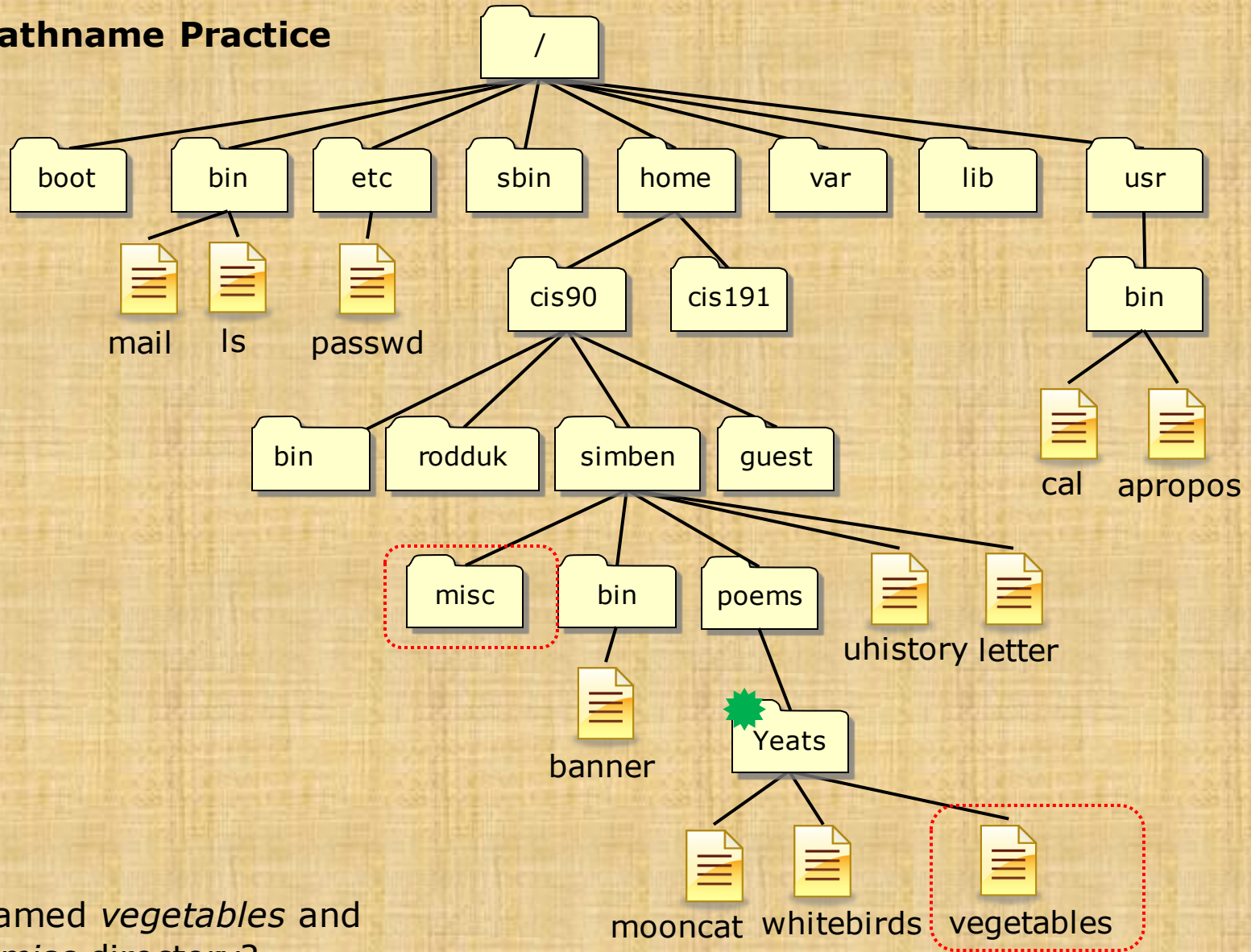

From  how does Benji:

Create a file named *vegetables* and move it to his *misc* directory?

## File Tree Pathname Practice

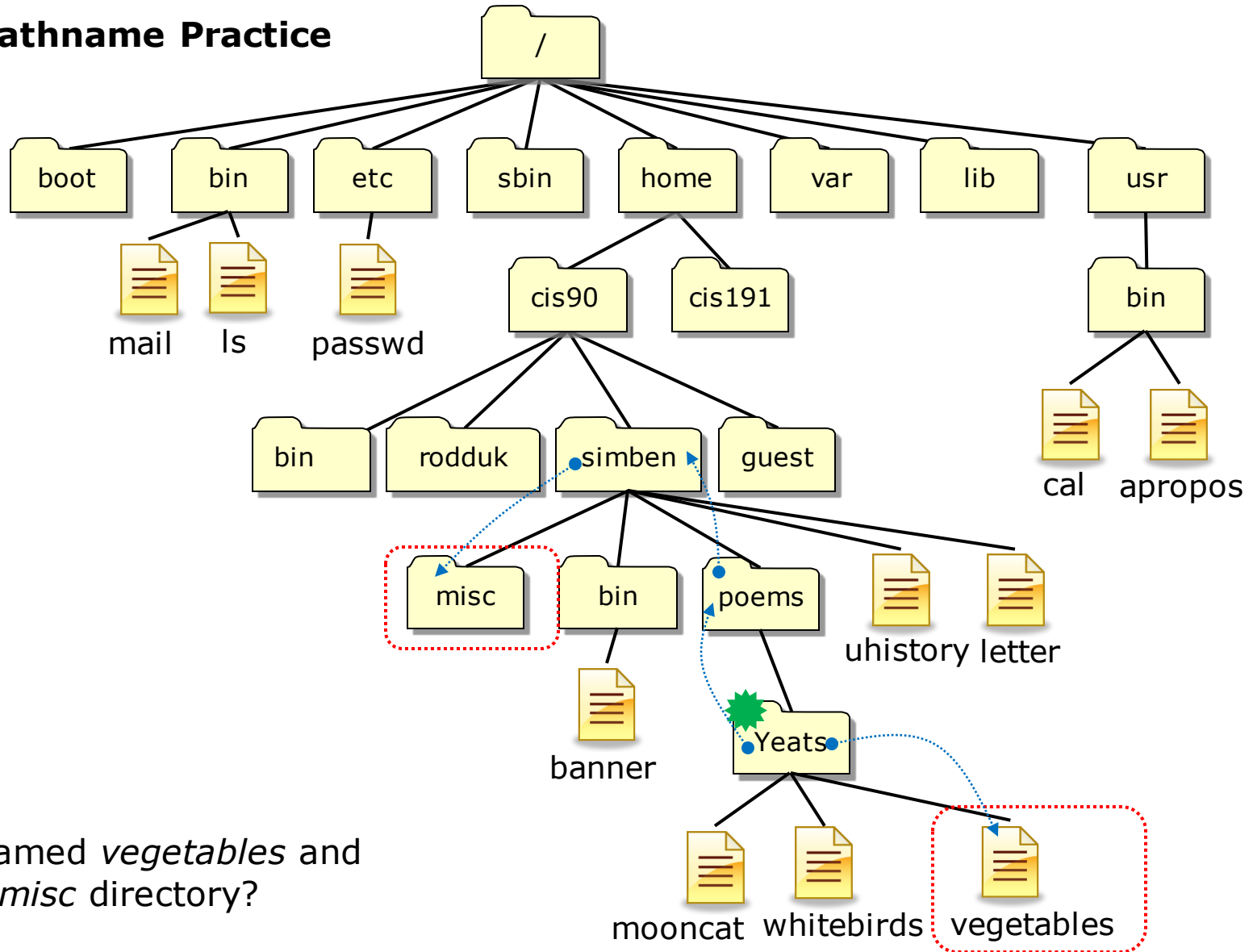

From  how does Benji:

Create a file named *vegetables* and move it to his *misc* directory?

```

/home/cis90/simben/poems/Yeats $ touch vegetables
/home/cis90/simben/poems/Yeats $ mv vegetables ../../misc/
    
```

Other answers  
are also  
acceptable

From  how  
does Benji:

Create a file named *vegetables* and  
move it to his *misc* directory?

**touch vegetables**

**mv <path-to-file> <path-to-directory>**

**mv vegetables ../../misc/**

**or mv vegetables /home/cis90/simben/misc/**

**or mv /home/cis90/simben/poems/Yeats/vegetables ../../misc/**

**or mv /home/cis90/simben/poems/Yeats/vegetables /home/cis90/simben/misc/**

**or mv vegetables ~/misc/**

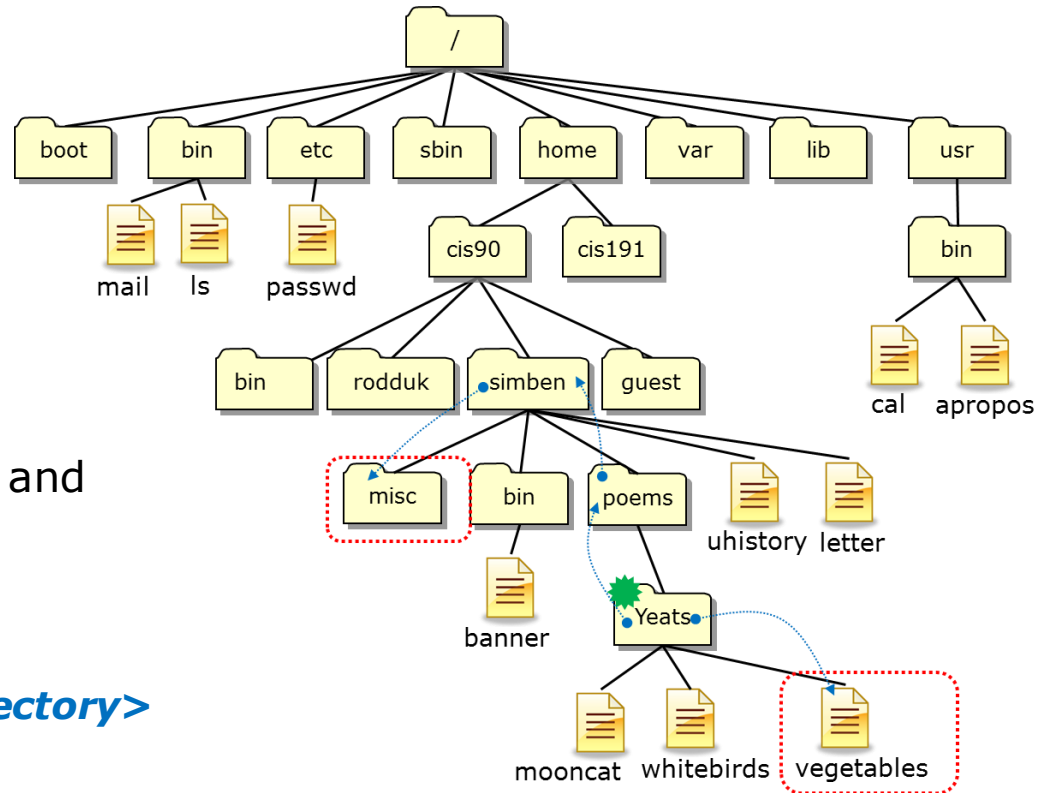

File Tree Pathname Practice

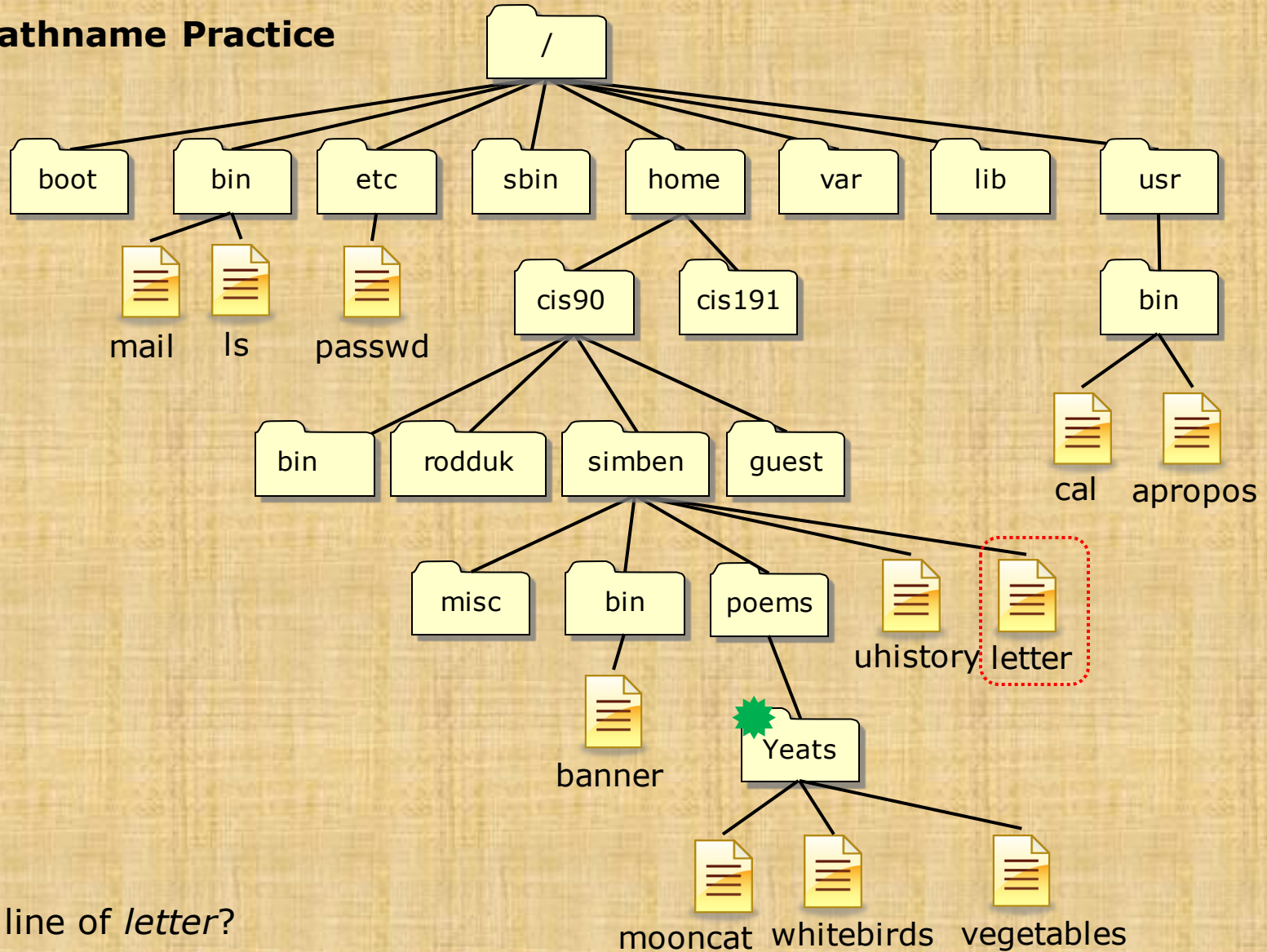

From ★ how does Benji:

Print the last line of *letter*?



## File Tree Pathname Practice

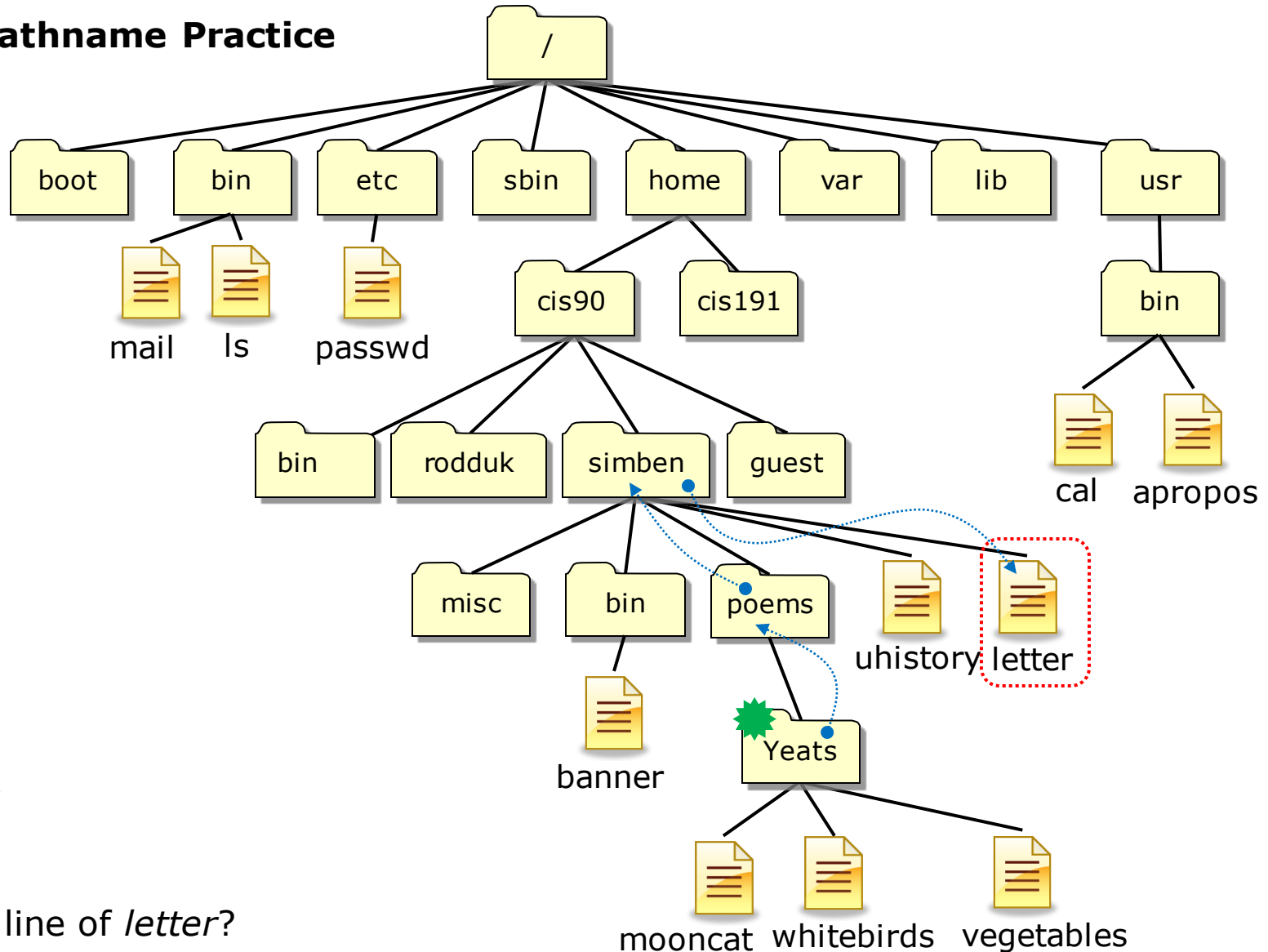

From  how  
does Benji:

Print the last line of *letter*?

`/home/cis90/simben/poems/Yeats $ tail -n1 ../../letter`

Other answers  
are also  
acceptable

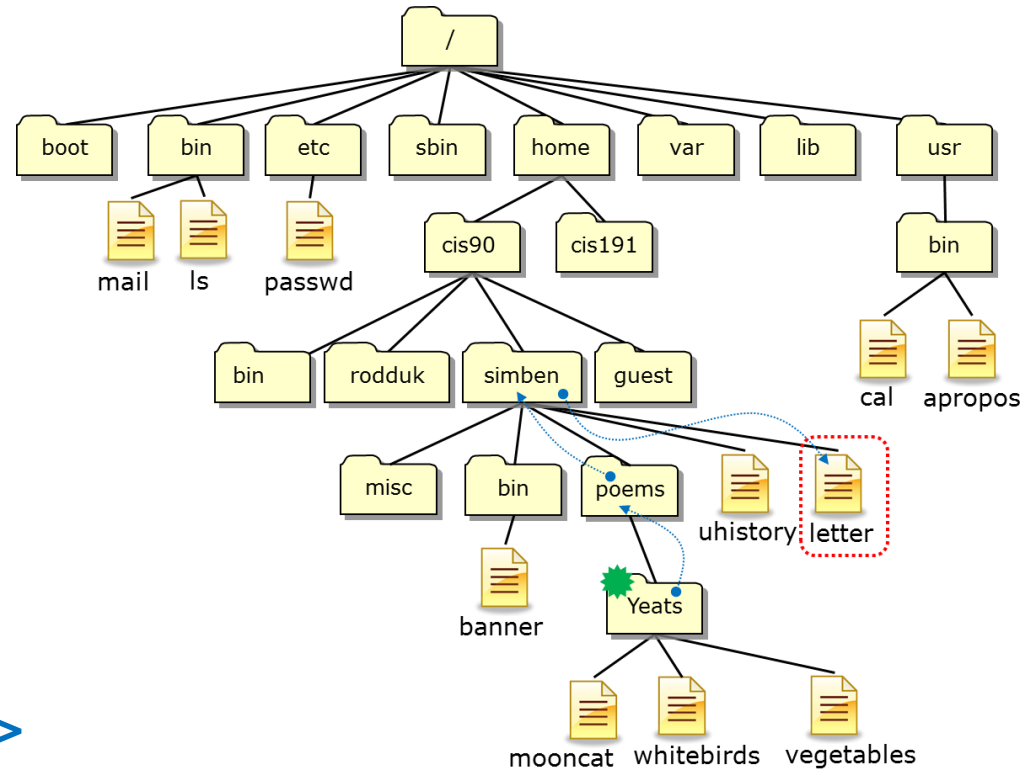

From  how  
does Benji:

Print the last line of *letter*?

**tail -n<number> <path-to-file>**

**tail -n1 ../../letter**

**or tail -n1 /home/cis90/simben/letter**

**or tail -n1 ~/letter**

*All these answers are correct*

File Tree Pathname Practice

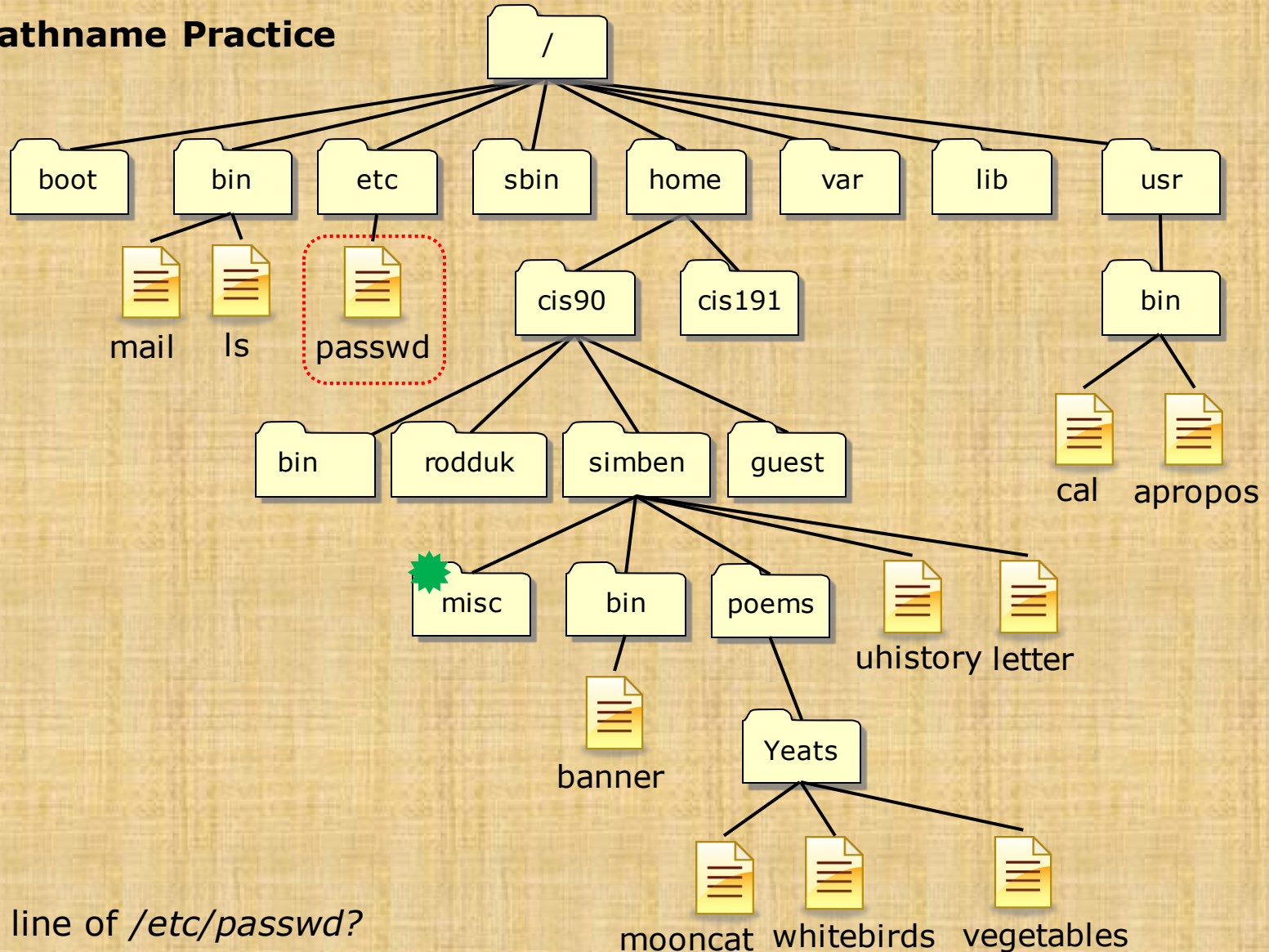

From  how does Benji:

Print the first line of `/etc/passwd`?

## File Tree Pathname Practice

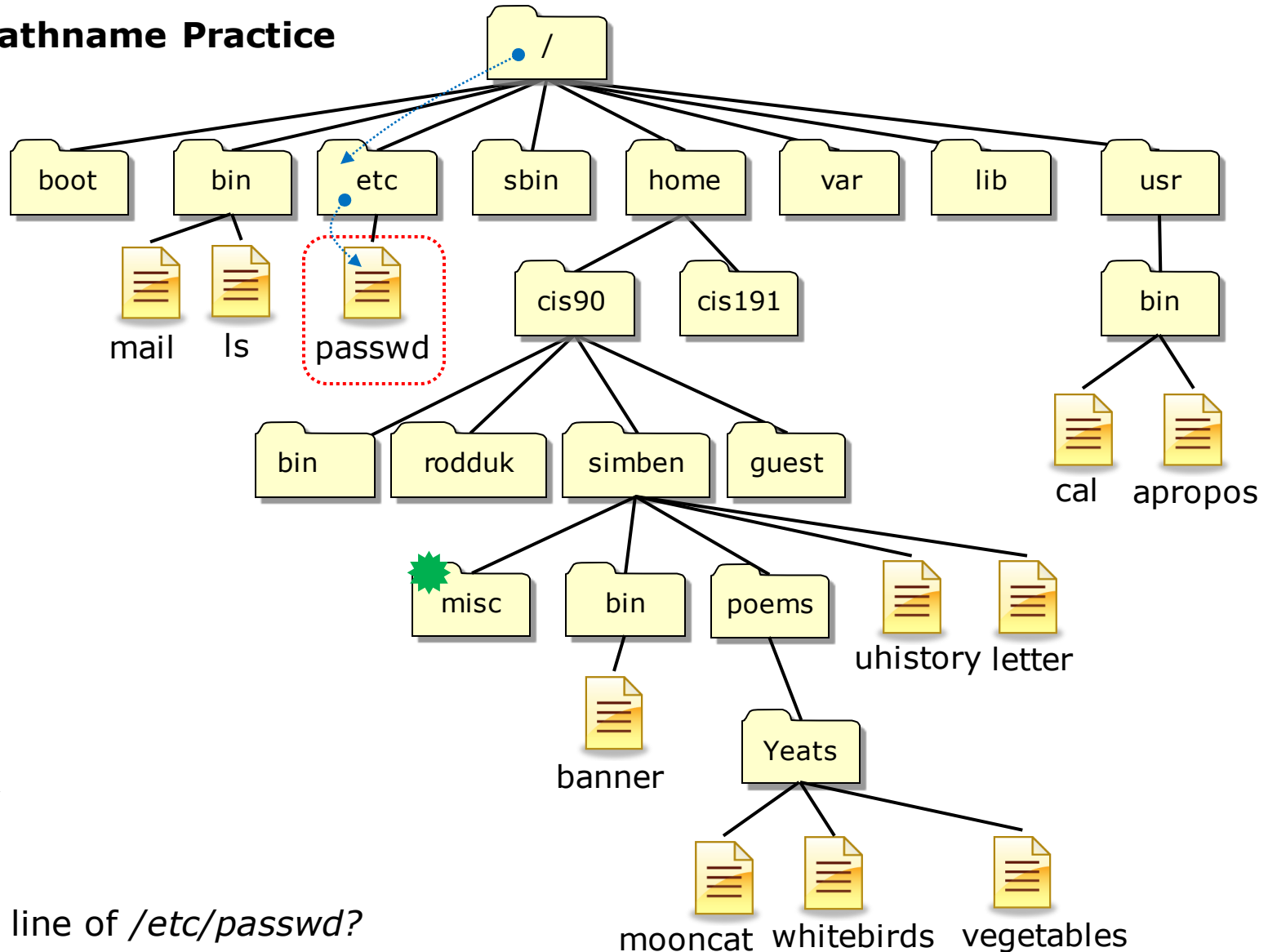

From  how  
does Benji:

Print the first line of `/etc/passwd`?

```
/home/cis90/simben/misc $ head -n1 /etc/passwd
```

*Other answers are also acceptable*

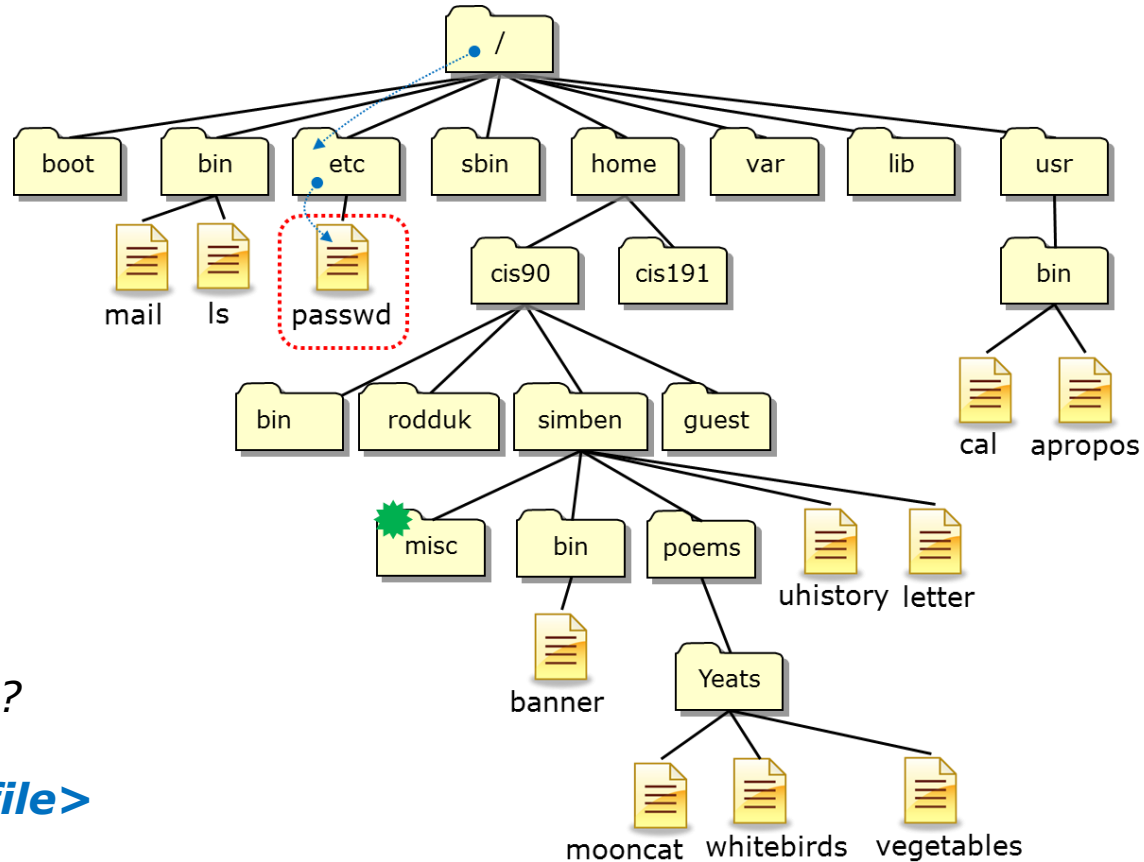

From  how does Benji:

Print the first line of `/etc/passwd`?

**`head -n<number> <path-to-file>`**

*or* **`head -n1 /etc/passwd`**

*or* **`head -n1 ../../../../../../etc/passwd`**

*Both these answers are correct*



### File Tree Pathname Practice

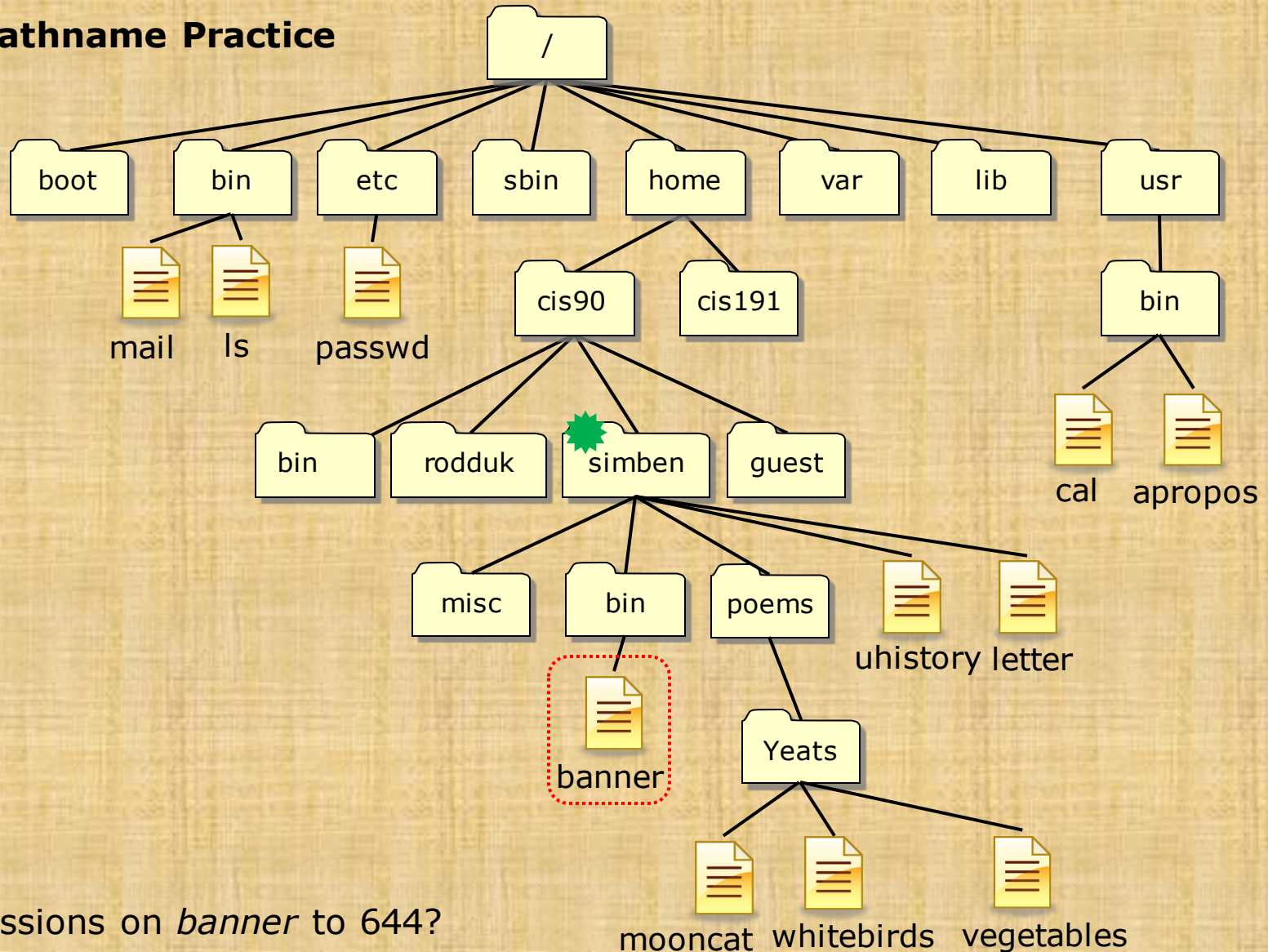

From  how does Benji:

Change permissions on *banner* to 644?

## File Tree Pathname Practice

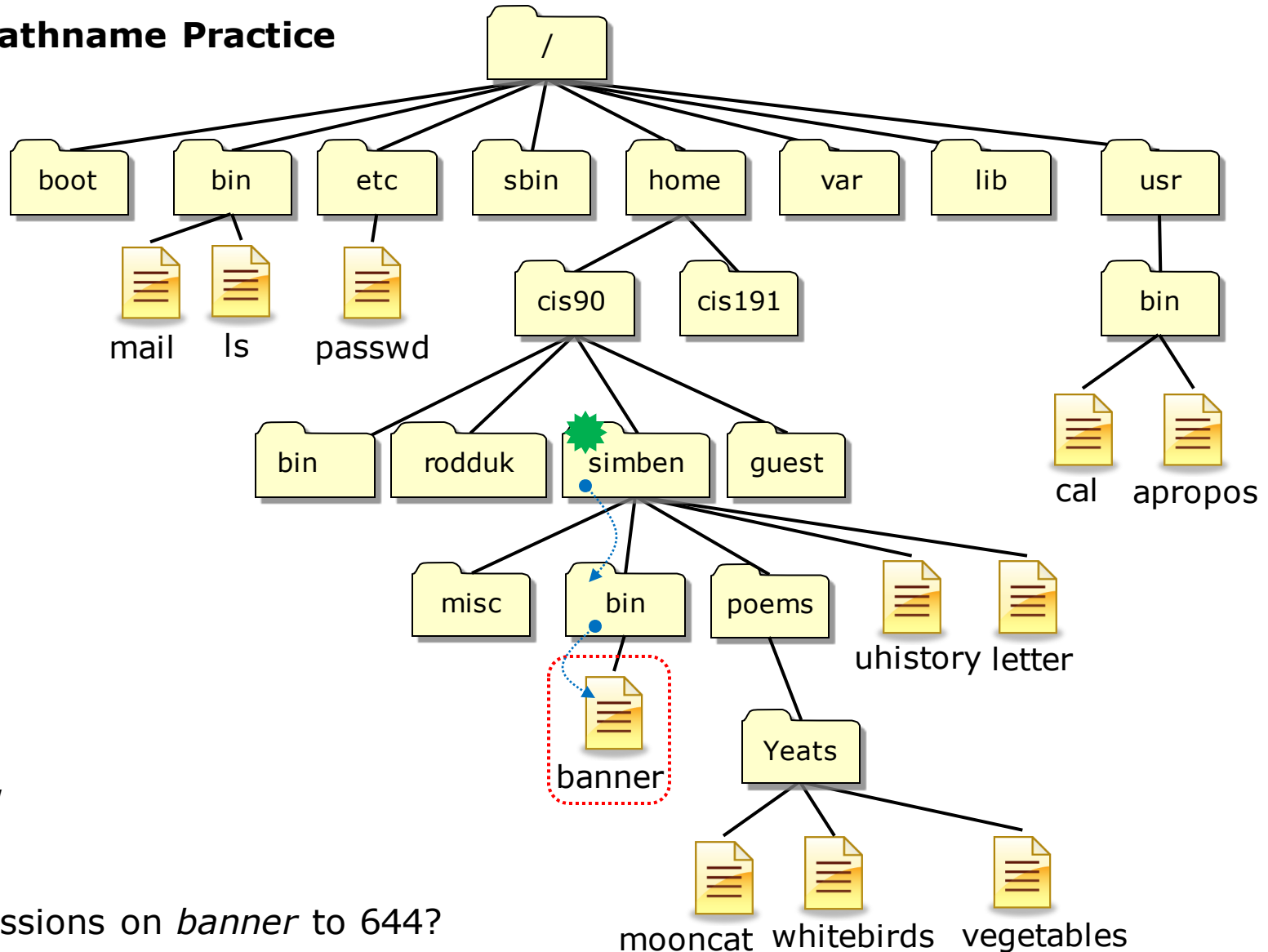

From  how does Benji:

Change permissions on *banner* to 644?

```
/home/cis90/simben $ chmod 644 bin/banner
```

Other answers  
are also  
acceptable

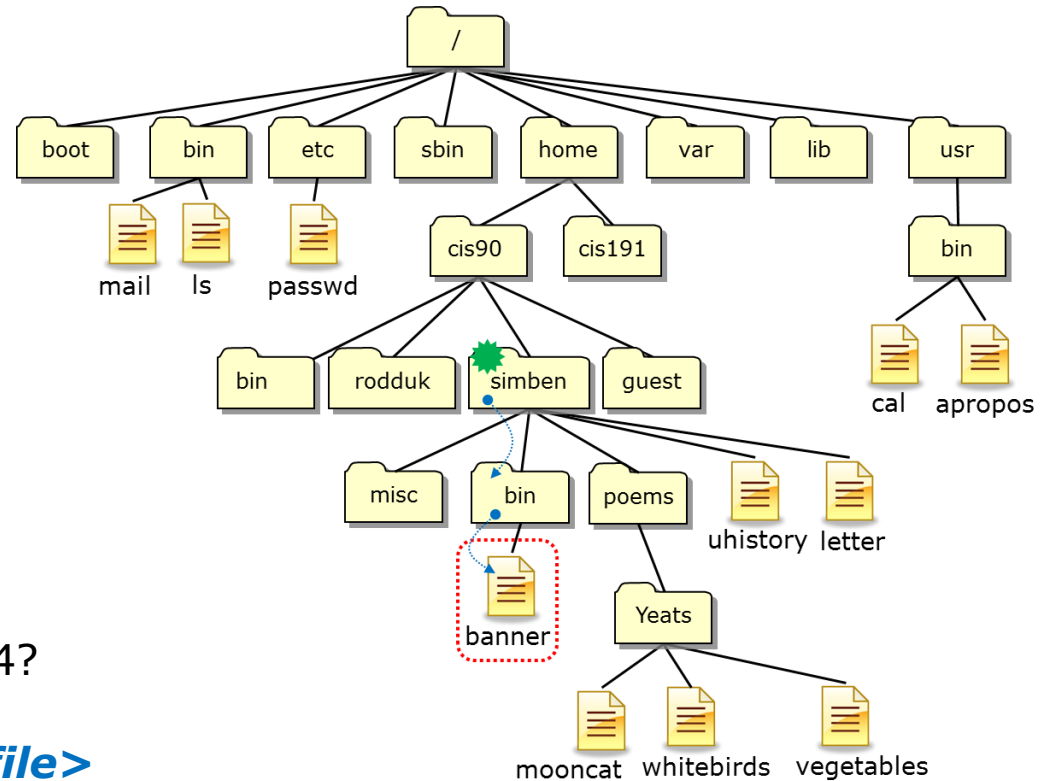

From  how  
does Benji:

Change permissions on *banner* to 644?

**chmod <permissions> <path-to-file>**

or **chmod 644 bin/banner**

or **chmod 644 /home/cis90/simben/bin/banner**

Both these answers are correct

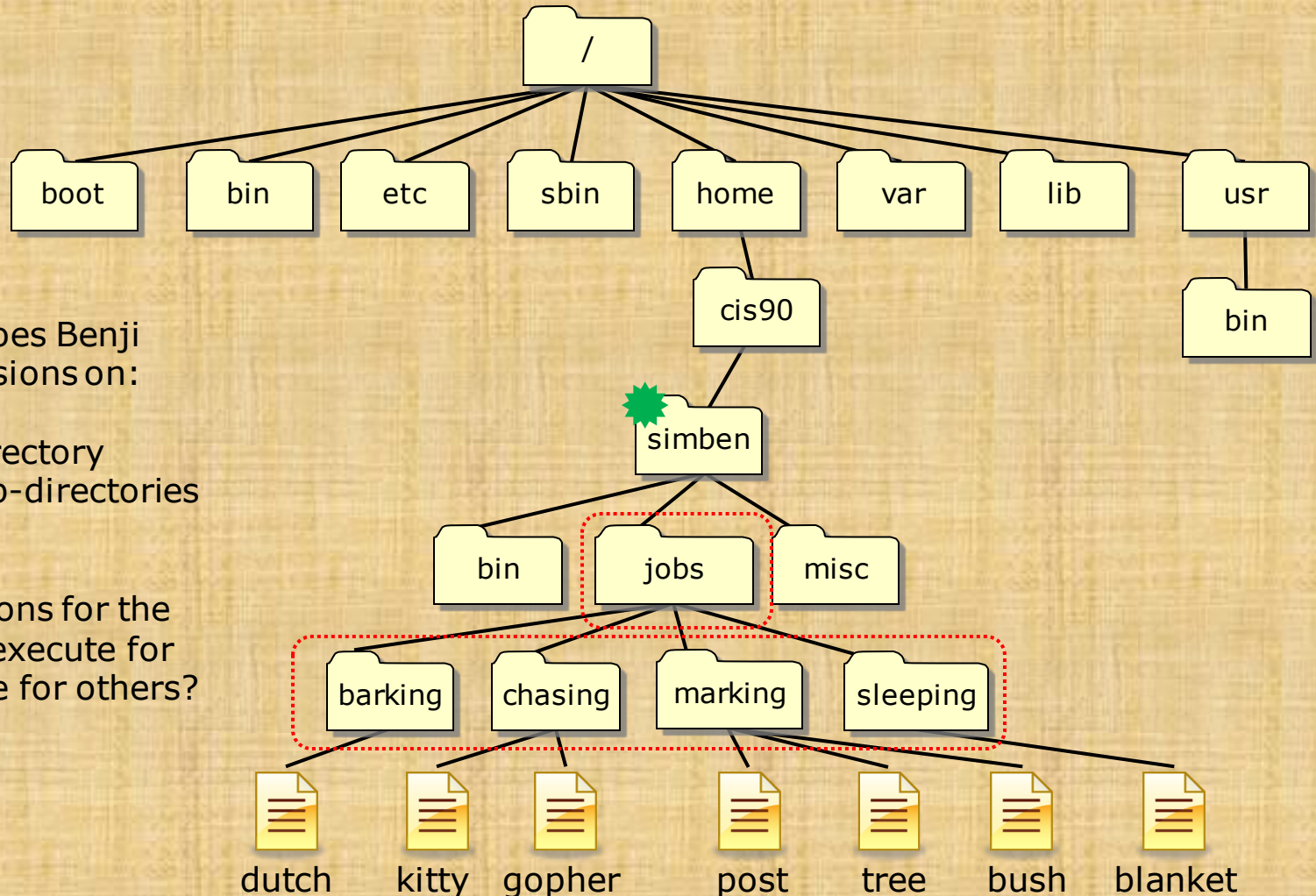

From  how does Benji change permissions on:

1. His *jobs/* directory
2. The four sub-directories under *jobs/*

to full permissions for the owner, read & execute for group and none for others?

You can make your own jobs directory by issuing:  
**cd**  
**tar xvf ../depot/jobs.tar**

## This works

```
chmod 750 jobs
cd jobs
chmod 750 barking
chmod 750 chasing
chmod 750 marking
chmod 750 sleeping
```

## So does this

```
chmod 750 jobs
chmod 750 jobs/barking
chmod 750 jobs/chasing
chmod 750 jobs/marketing
chmod 750 jobs/sleeping
```

## And this

```
chmod 750 jobs
chmod 750 jobs/barking/ jobs/chasing/ jobs/marketing/ jobs/sleeping/
```

## This is better though

```
chmod 750 jobs
chmod 750 jobs/*
```

## I like this the best!

```
chmod 750 jobs jobs/*
```

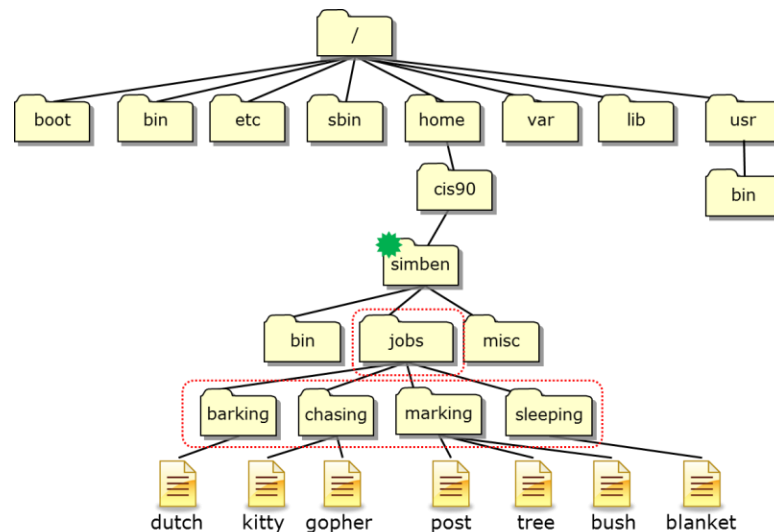

*And so ... which way did you do step 9 in Lab 6?*



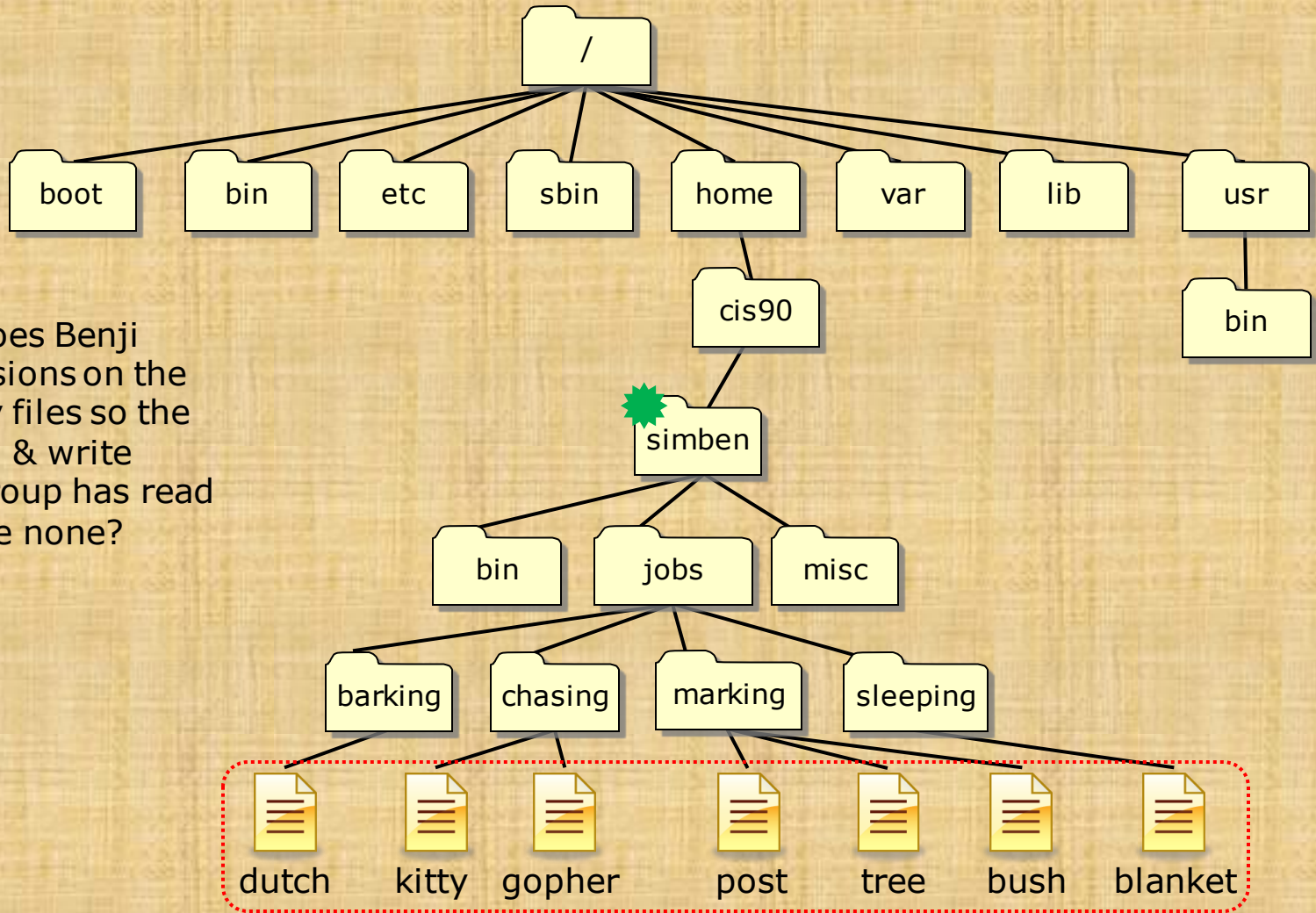

From  how does Benji change permissions on the circled ordinary files so the owner has read & write permissions, group has read and others have none?

*This will always work*

```
cd jobs
cd barking
chmod 640 dutch
cd ..
cd chasing
chmod 640 kitty
chmod 640 gopher
cd ..
cd marking
chmod 640 post tree bush
cd ..
cd marking
chmod 640 post
chmod 640 tree
chmod 640 bush
cd ..
cd sleeping
chmod 640 blanket
cd
```

*This works too*

```
cd jobs
cd barking
chmod 640 dutch
cd ..
cd chasing
chmod 640 kitty gopher
cd ..
cd marking
chmod 640 post tree bush
cd ..
cd sleeping
chmod 640 blanket
cd
```

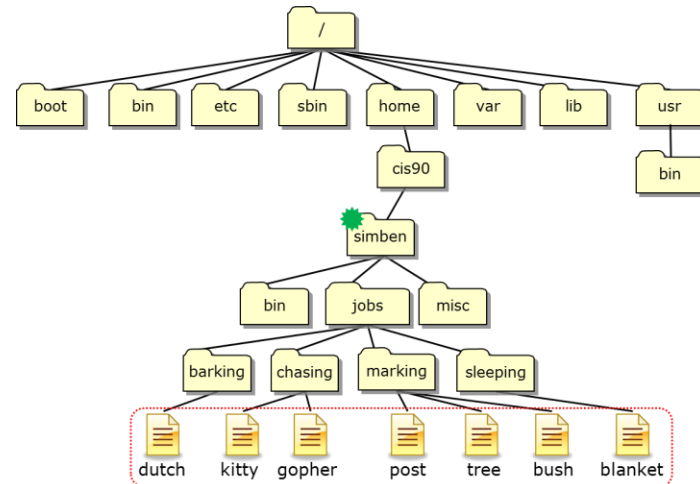

*So will this*

```
cd jobs
cd barking
chmod 640 *
cd ..
cd chasing
chmod 640 *
cd ..
cd marking
chmod 640 *
cd ..
cd sleeping
chmod 640 *
cd
```

*This is better*

```
cd jobs
chmod 640 barking/*
chmod 640 chasing/*
chmod 640 marking/*
chmod 640 sleeping/*
cd ..
```

*I like this the best!*

```
chmod 640 jobs/*/*
```

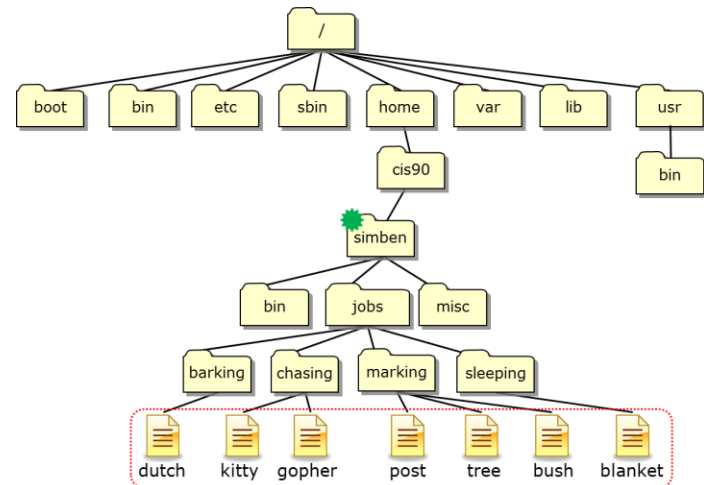

*And so ... which way did you do step 10 in Lab 6?*

File Tree Pathname Practice

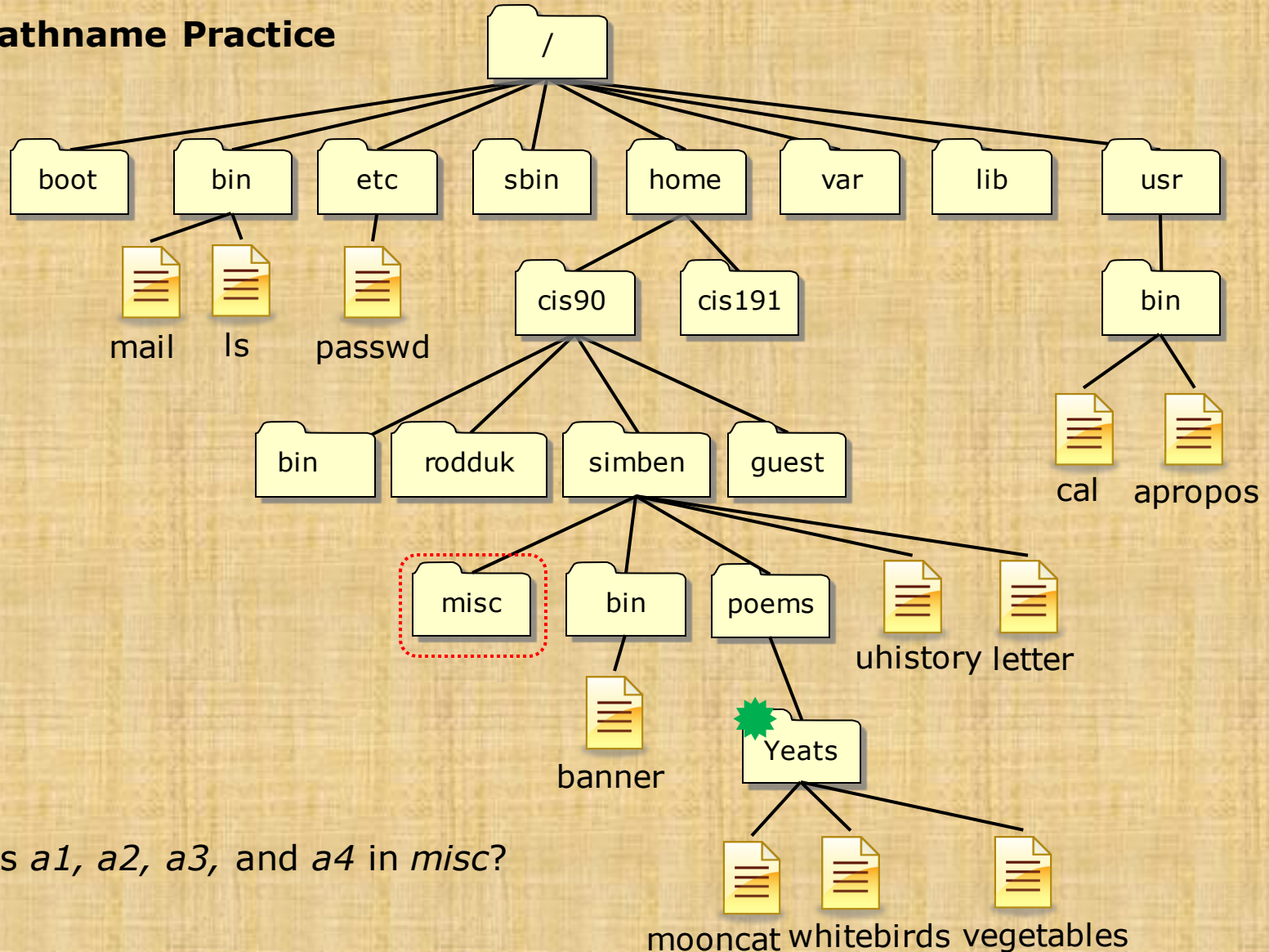

From  how does Benji:

Create new files *a1*, *a2*, *a3*, and *a4* in *misc*?

## File Tree Pathname Practice

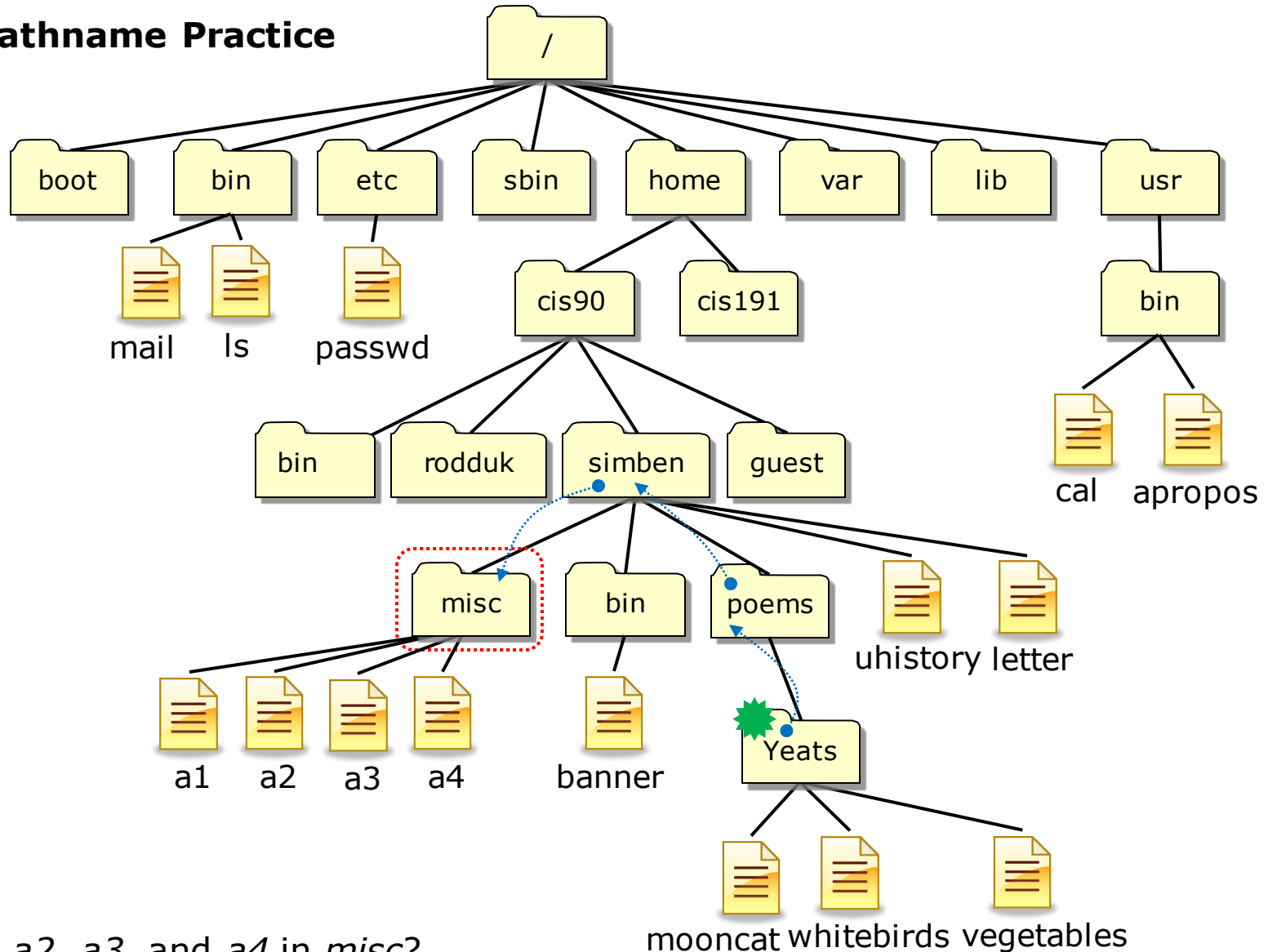

From  how does Benji:

Create files *a1*, *a2*, *a3*, and *a4* in *misc*?

`/home/cis90/simben/poems/Yeats $ touch ../../misc/a1 ../../misc/a2 ../../misc/a3 ../../misc/a4`



Other answers  
are also  
acceptable

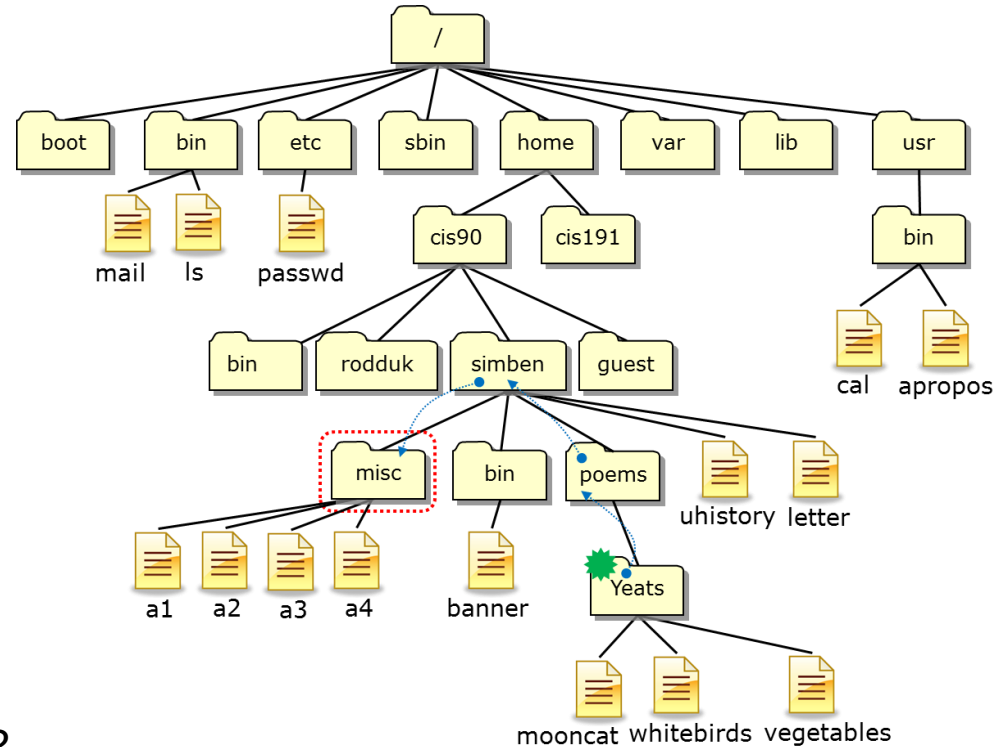

From  how  
does Benji:

Create files *a1*, *a2*, *a3*, and *a4* in *misc*?

**touch <path-to-file> <path-to-file> <path-to-file> <path-to-file>**

**touch ../../misc/a1 ../../misc/a2 ../../misc/a3 ../../misc/a4**

**or touch ~/misc/a1 ~/misc/a2 ~/misc/a3 ~/misc/a4**

**or touch /home/cis90/simben/misc/a1 /home/cis90/simben/misc/a2  
/home/cis90/simben/misc/a3 /home/cis90/simben/misc/a4 (all on one line)**

All these answers are correct



*For the aspiring gurus  
there is an even better  
way to do the last  
operation!*

File Tree Pathname Practice

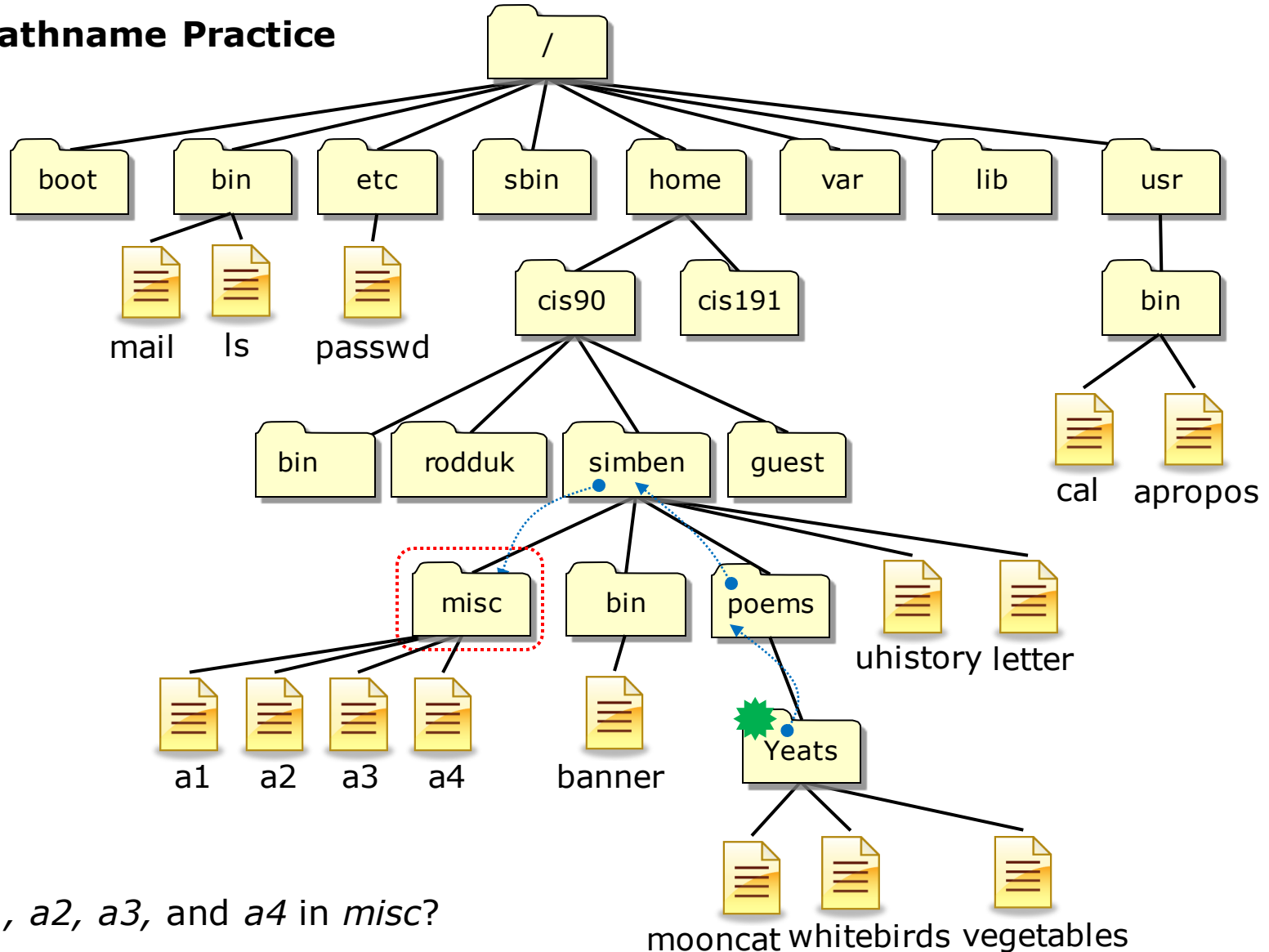

From  how does Benji:

Create files *a1*, *a2*, *a3*, and *a4* in *misc*?

```
/home/cis90/simben/poems/Yeats $ touch ~/misc/a{1,2,3,4}
```



# umask continued

## Why umask?

Allows users and system administrators to disable specific permissions on new files and directories when they are created.

*Unlike **chmod**, it does **NOT** change the permissions on existing files or directories.*



## umask summary

To determine permissions on a new file or directory apply the umask to the initial starting permissions:

- For new files, start with **666**
- For new directories, start with **777**
- For file copies, start with **the permission on the source file**



## Case 1 – a new directory

**With a umask of 033 what permissions would a newly created DIRECTORY have?**

*Write your answer in the chat window*

## Case 1 – a new directory

**With a umask of 033 what permissions would a newly created DIRECTORY have?**

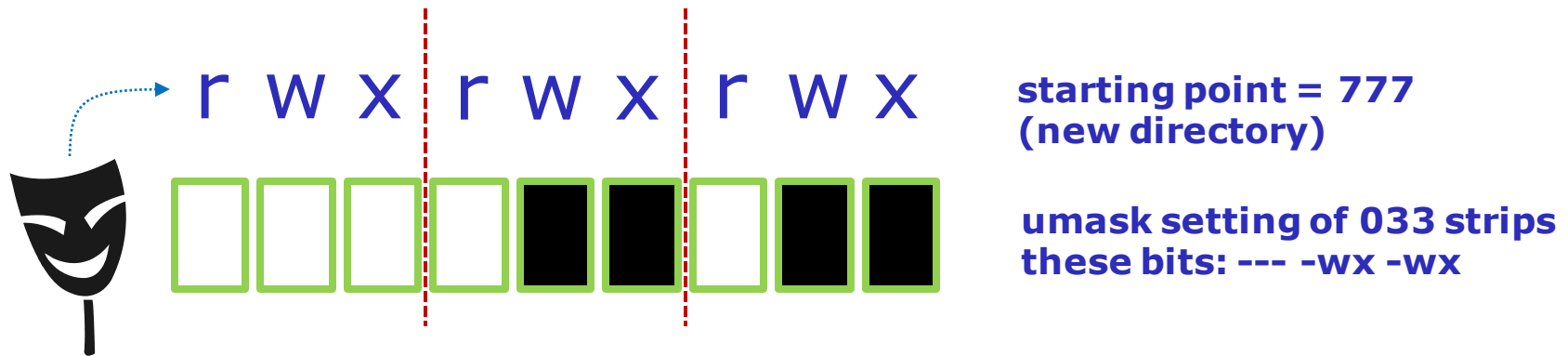

*Now slide the mask up and over the starting point permissions*

## Case 1 – a new directory

With a umask of 033 what permissions would a newly created DIRECTORY have?

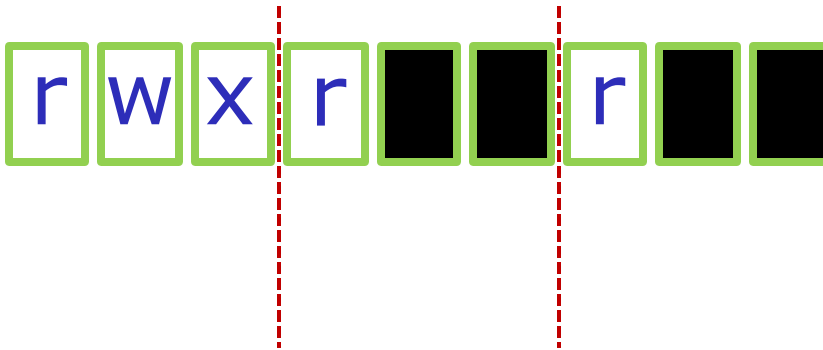

starting point = 777  
(new directory)

umask setting of 033 strips  
these bits: --- -wx -wx

**Answer: 744**

*Prove it to yourself on Opus as shown here*

```
/home/cis90ol/simmsben $ umask 033
/home/cis90ol/simmsben $ mkdir brandnewdir
/home/cis90ol/simmsben $ ls -ld brandnewdir/
drwxr--r-- 2 simmsben cis90ol 4096 Apr 21 12:46 brandnewdir/
 7 4 4
```

## Case 2 – new file

**With a umask of 077 what permissions would a newly created FILE have?**

*Write your answer in the chat window*

## Case 2 – new file

With a umask of 077 what permissions would a newly created FILE have?

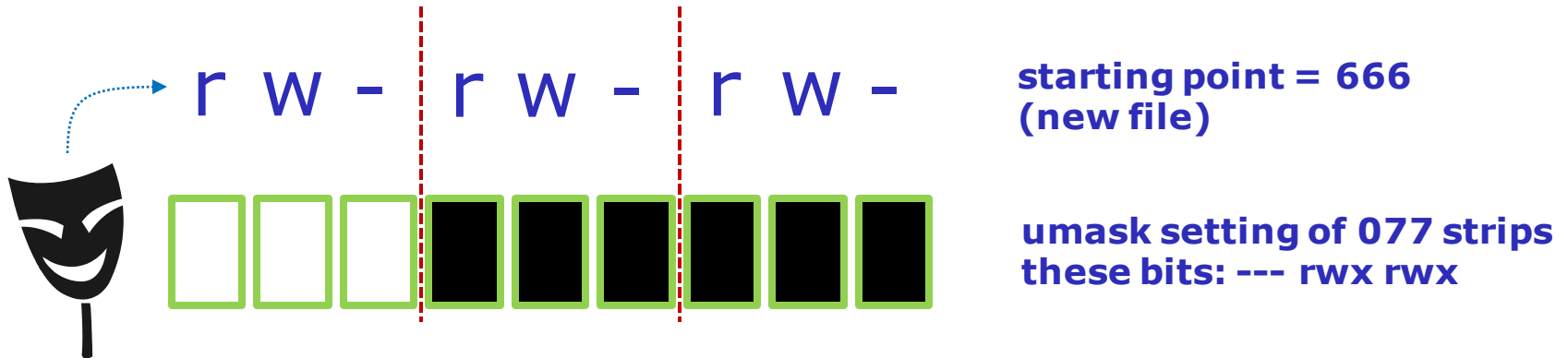

*Now slide the mask up and over the starting point permissions*



## Case 2 – new file

With a umask of 077 what permissions would a newly created FILE have?

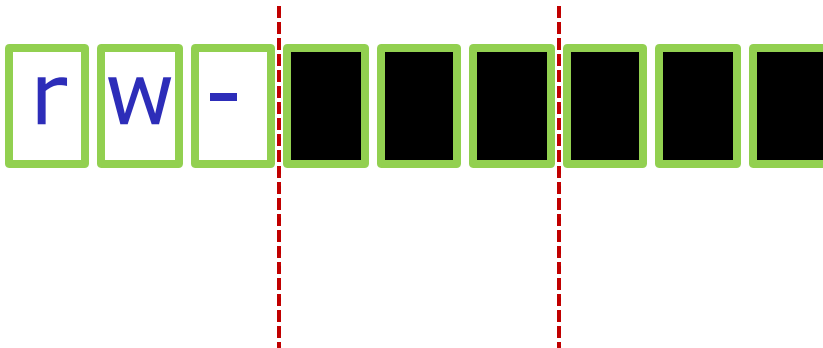

starting point = 666  
(new file)

umask setting of 077 strips  
these bits: --- rwx rwx

**Answer: 600**

*Prove it to yourself on Opus as shown here*

```

/home/cis90ol/simmsben $ umask 077
/home/cis90ol/simmsben $ touch brandnewfile
/home/cis90ol/simmsben $ ls -l brandnewfile
-rw----- 1 simmsben cis90ol 0 Apr 21 12:50 brandnewfile
 6 0 0
  
```

## Case 3 – file copy

**If umask=066 and the *cinderella* file permissions are 440  
What would the permissions be on *cinderella.bak* after:  
cp cinderella cinderella.bak**

*Write your answer in the chat window*

## Case 3 – file copy

If `umask=066` and the *cinderella* file permissions are `440`  
 What would the permissions be on *cinderella.bak* after:  
`cp cinderella cinderella.bak`

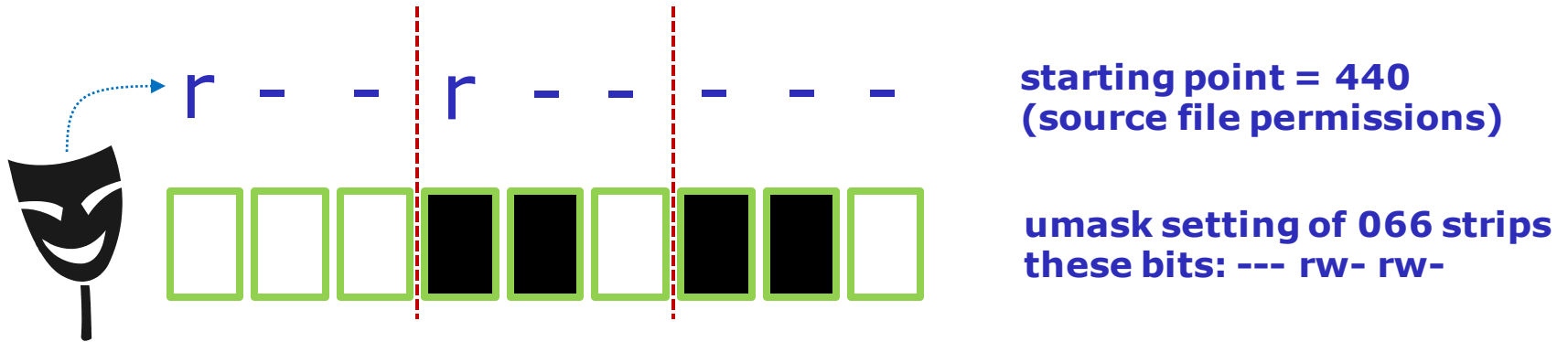

*Now slide the mask up and over the starting point permissions*

## Case 3 – file copy

If `umask=066` and the *cinderella* file permissions are 440  
 What would the permissions be on *cinderella.bak* after:  
`cp cinderella cinderella.bak`

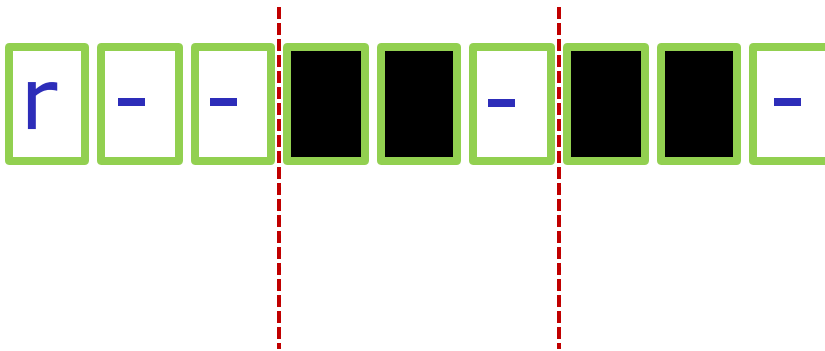

starting point = 440  
 (source file permissions)

umask setting of 066 strips  
 these bits: --- rw- rw-

**Answer: 400**

*Prove it to yourself on Opus as shown here*

```
/home/cis90/simben $ touch cinderella
/home/cis90/simben $ chmod 440 cinderella
/home/cis90/simben $ umask 066
/home/cis90/simben $ cp cinderella cinderella.bak
/home/cis90/simben $ ls -l cinderella.bak
-r----- . 1 simben90 cis90 0 Oct 22 09:17 cinderella.bak
 4 0 0
```



# Housekeeping



## Previous material and assignment

1. Lab 6 due 11:59PM
2. A **check6** script is available



**Don't forget to submit your final Lab 6!**

3. Five more posts due 11:59PM
4. Early preview of Lab X2 is now available. This is recommended for anyone wanting more practice with pathnames.



## Last Call -- Perkins/VTEA Survey

Log on to WEBADVISOR at <https://wave.cabrillo.edu>

Select “STUDENTS: Click Here” (navy blue bar)

- Under “Academic Profile” Click on “Student Update Form”
- Use drop down list under “Select the earliest term for which you are registered” and click on the current term.
- Select “SUBMIT”

Scroll down to the “Career Technical Information”

- Answer questions by clicking on the circle to the left of your “Yes” or “No” answers
- You can get details about a question by clicking on blue underlined phrase
- After answering all questions Select “SUBMIT”

Then “LOG OUT”

*This is an important source of funding for Cabrillo College.*

*Send me an email stating you completed this survey for **three points extra credit!***

<b>Career Technical Information</b>	
Your answers to these questions will help qualify Cabrillo College for Perkins/VTEA grant funds.	
Are you currently receiving benefits from:	
<input type="radio"/> Yes	TANF/CALWORKS
<input checked="" type="radio"/> No	
<input type="radio"/> Yes	SSI (Supplemental Security Income)
<input checked="" type="radio"/> No	
<input type="radio"/> Yes	GA (General Assistance)
<input checked="" type="radio"/> No	
<input type="radio"/> Yes	Does your <u>income</u> qualify you for a fee waiver?
<input checked="" type="radio"/> No	
<input type="radio"/> Yes	Are you a single parent with custody of one or more minor children?
<input checked="" type="radio"/> No	
<input type="radio"/> Yes	Are you a <u>displaced homemaker</u> attending Cabrillo to develop job skills?
<input checked="" type="radio"/> No	
<input type="radio"/> Yes	Have you moved in the preceding 36 months to obtain, or to accompany parents or spouses to obtain, temporary or seasonal employment in agriculture, dairy, or fishing?
<input checked="" type="radio"/> No	

**IIED** Institute for Innovation &  
Economic Development  
CSU Monterey Bay | College of Business **PRESENTS**

## STARTUP HACKATHON MONTEREY BAY

### Creating Digital Games



Startup Hackathon Monterey Bay is a 3-day technology development competition that brings together teams of students and others to design, develop and apply technology to solve community problems.

This year, teams of students and others will produce digital games that solve community problems in fun and engaging ways.

Registration includes 6 meals, a t-shirt and lots of coffee and snacks to keep participants fueled up all weekend.

**Students are encouraged to bring laptops.**

For questions or disability accommodations, please contact [innovation@csumb.edu](mailto:innovation@csumb.edu)

**Date:** November 4th– 6th  
**Time:** 4 p.m. Nov 4th – 4 p.m. Nov. 6th  
**Place:** CSUMB BIT Building (1st Floor)  
**Cost:** FREE! For Cabrillo Students with Promo Code

For more information visit [csumb.edu/iied](http://csumb.edu/iied)

#### SPONSORED BY



**Pre-registration is required at**  
<https://startuphackathon2016.eventbrite.com>



Register for free with promo code:

**cHack2016**

Scan the code to register



## Where to find your grades

**Send me your survey to get your LOR code name.**

### The CIS 90 website Grades page

<http://simms-teach.com/cis90grades.php>

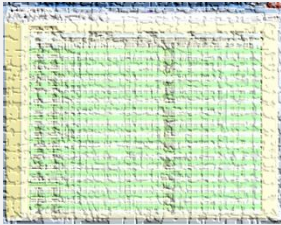

### Or check on Opus

**checkgrades** *codename*  
(where codename is your LOR codename)

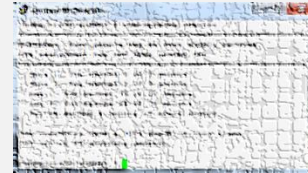

Written by Jesse Warren a past CIS 90 Alumnus

Percentage	Total Points	Letter Grade	Pass/No Pass
90% or higher	504 or higher	A	Pass
80% to 89.9%	448 to 503	B	Pass
70% to 79.9%	392 to 447	C	Pass
60% to 69.9%	336 to 391	D	No pass
0% to 59.9%	0 to 335	F	No pass

**At the end of the term I'll add up all your points and assign you a grade using this table**

### Points that could have been earned:

5 quizzes: 15 points  
 5 labs: 150 points  
 1 test: 30 points  
 1 forum quarter: 20 points  
**Total: 215 points**



# New commmands



## Lesson 8 commands for your toolbox



**find** - Find file or content of a file



**grep** - "Global Regular Expression Print"



**sort** - sort



**spell** - spelling correction

**wc** - word count



**tee** - split output



**cut** - cut fields from a line

# sort command



# sort command

## Basic syntax

(see man page for the rest of the story)

**sort** *<options>* *<filepath>*

The **sort** command can read lines from a file or *stdin* and sort them.

The **-r** option will do a reverse sort

# Activity

Get the *names* file to use for the next series of slides

```
/home/cis90/simben $ cd
```

*return to home directory*

```
/home/cis90/simben $ cp ../depot/names .
```

*relative path to the names file in the depot directory*

*Think of the single dot file as "here" (it is hard linked to the current directory)*

```
/home/cis90/simben $ cat names  
duke  
benji  
star  
homer
```

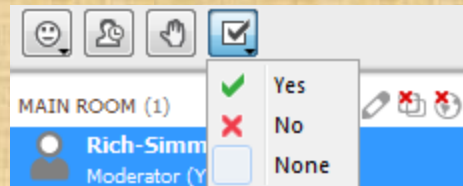

*Give me a green Yes check if you get the same results*

Pretend you are a  
command  
(use your great  
imagination)

**Shell Steps**

- 1) Prompt
- 2) Parse
- 3) Search
- 4) Execute
- 5) Nap
- 6) Repeat

*Let's visualize being the sort program and being loaded into memory and executing*



A day in the life of a process

*Looking around you notice there is one  
in tray and two out trays*

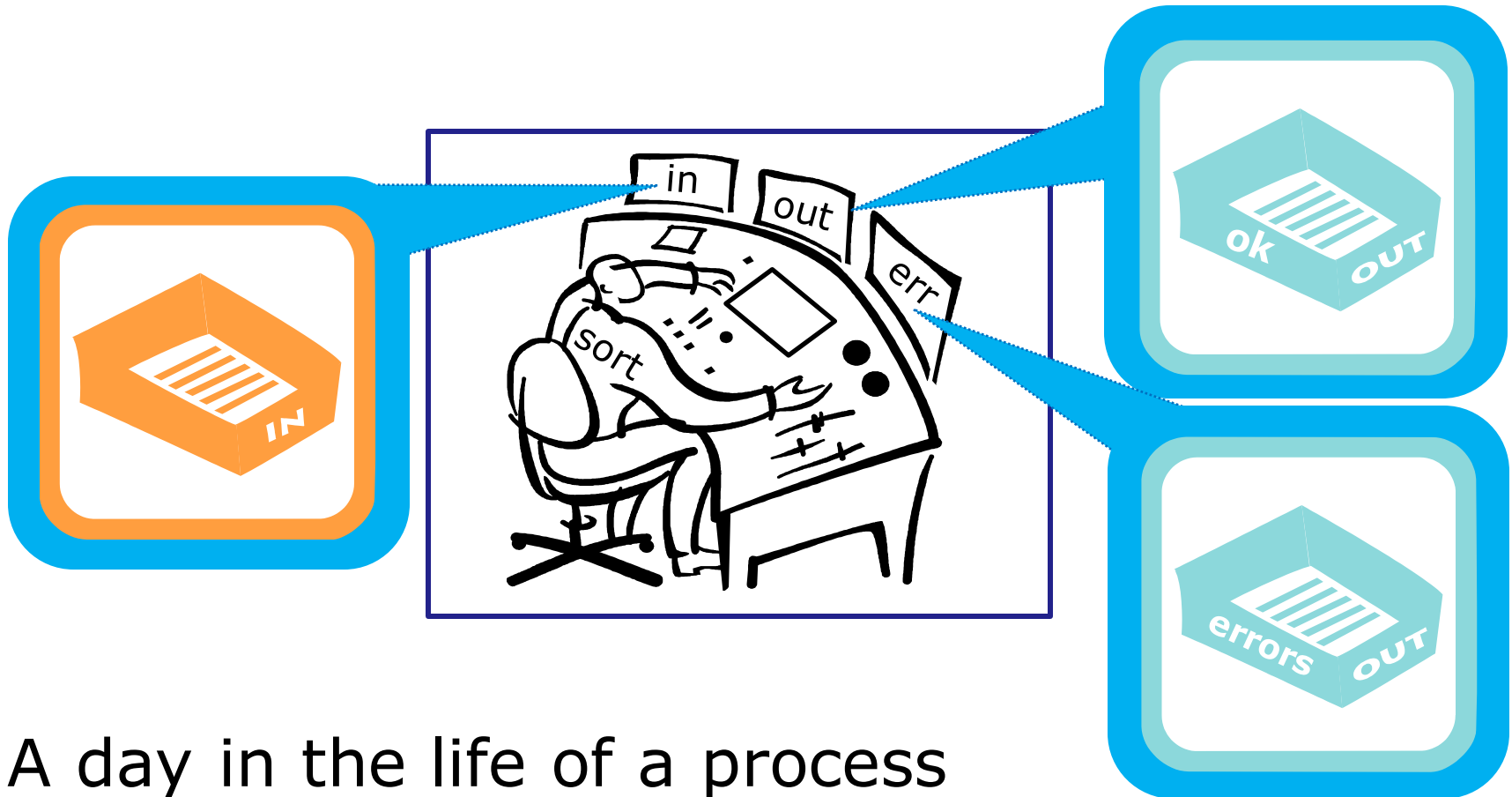

A day in the life of a process

*You also notice an instruction window on your desk. This is where you find out about any options or arguments the shell passes on to you.*

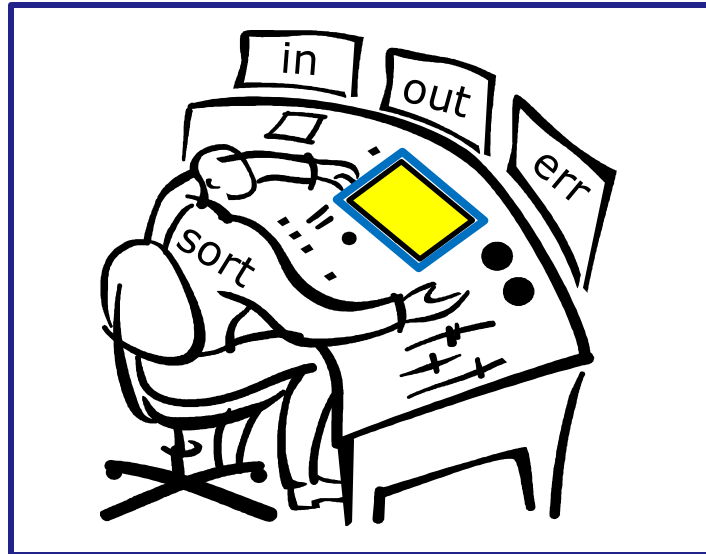
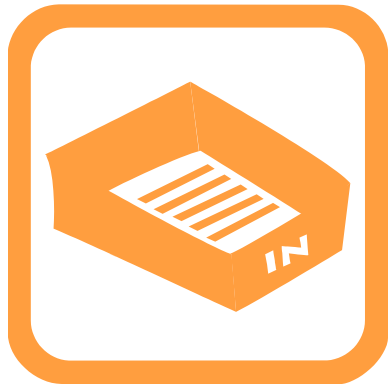

A day in the life of a process





# sort

## deep dive

## examples

# **sort** <good *filepath*>

```
/home/cis90/simben $ sort names  
benji  
duke  
homer  
star  
/home/cis90/simben $
```

*One argument  
which is a  
filename*

## Activity

### sort command with a filename argument

```
/home/cis90/simben $ cat names
```

```
duke  
benji  
star  
homer
```

```
/home/cis90/simben $ sort names
```

```
benji  
duke  
homer  
star
```

*The sort command will sort the lines in a file and output the sorted lines*

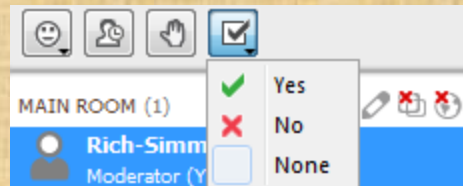

*Give me a green Yes check if you get the same results*

```
/home/cis90/simben $ sort names
```

### Shell Steps

- 1) Prompt
- 2) Parse
- 3) Search
- 4) Execute
- 5) Nap
- 6) Repeat

1. Prompt string is: `"/home/cis90/simben $ "`
2. Parsing results:
  - `command = sort`
  - no options
  - 1 argument = `"names"`
  - no redirection
3. Search user's path and locate the sort program in `/bin`
4. Sort loaded into memory and execution begins

**Shell Steps**

- 1) Prompt
- 2) Parse
- 3) Search
- 4) Execute
- 5) Nap
- 6) Repeat

/home/cis90/simben \$ **sort names**

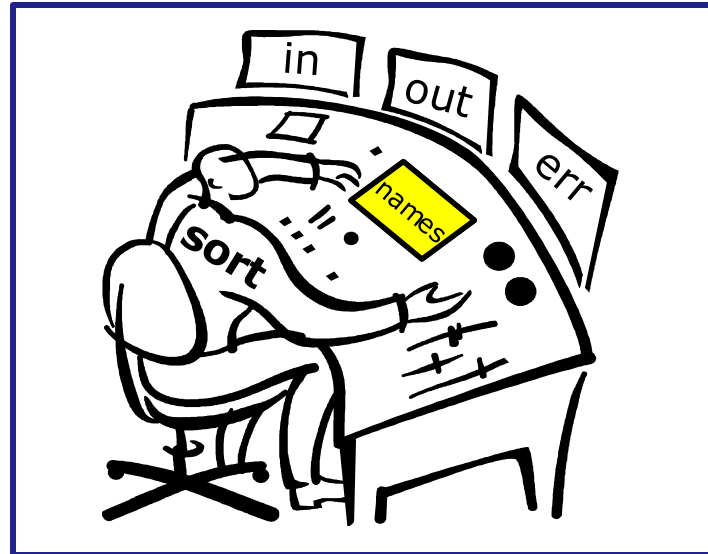
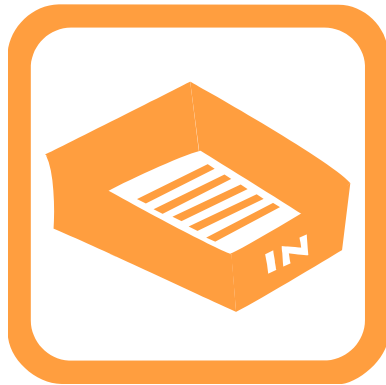

You (the sort process) check your instruction window and see the shell passed one argument "names" to you. You know (given your internal DNA code) that you must contact the kernel and request this file be opened and the contents read.

```
/home/cis90/simben $ sort names
```

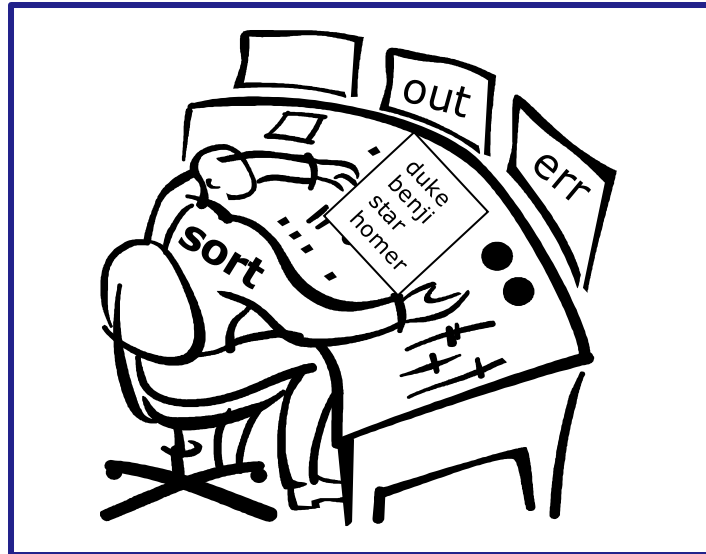
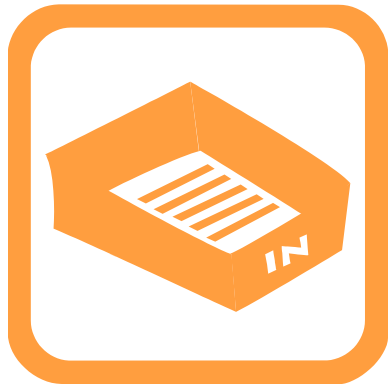

Note: Once the names file is opened you read in each line one at a time until you reach the EOF (End of File).



/home/cis90/simben \$ **sort names**

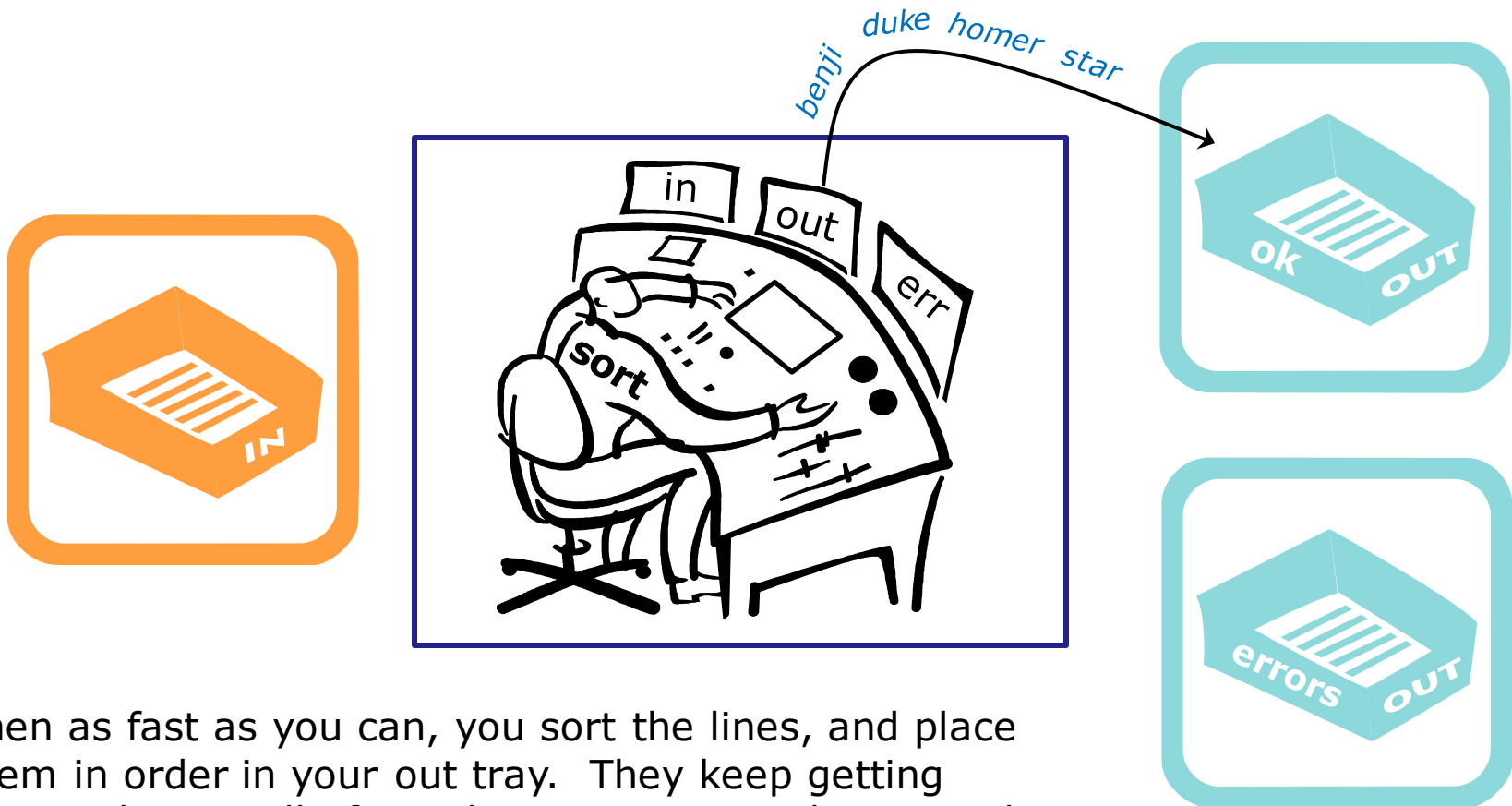

Then as fast as you can, you sort the lines, and place them in order in your out tray. They keep getting removed magically from the out tray. You have no idea where they go after that. You are done.

# sort (no args)

```
/home/cis90/simben $ sort  
kayla  
sky  
bella  
benji  
charlie  
bella  
benji  
charlie  
kayla  
sky  
/home/cis90/simben $
```

*No arguments  
specified*

*EOF*

# Activity

## sort command with no arguments

```
/home/cis90/simben $ sort
```

```
kayla
```

```
sky
```

```
bella
```

```
benji
```

```
charlie
```

```
bella
```

```
benji
```

```
charlie
```

```
kayla
```

```
sky
```

*If no filename was specified, **sort** will read input from the keyboard*

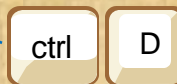

*Ctrl-D specifies the EOF (End Of File).*

*After sort receives the EOF it sorts the lines and outputs them*

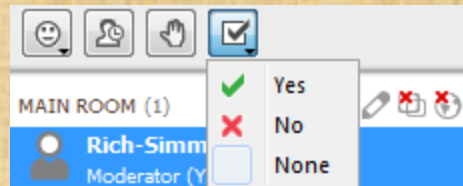

*Give me a green Yes check if you get the same results*

```
/home/cis90/simben $ sort
```

### Shell Steps

- 1) Prompt
- 2) Parse
- 3) Search
- 4) Execute
- 5) Nap
- 6) Repeat

1. Prompt string is: `"/home/cis90/simben $ "`
2. Parsing results:
  - `command = sort`
  - no options
  - no arguments
  - no redirection
3. Search user's path and locate the sort program in */bin*
4. Sort loaded into memory and execution begins

**Shell Steps**

- 1) Prompt
- 2) Parse
- 3) Search
- 4) Execute
- 5) Nap
- 6) Repeat

```
/home/cis90/simben $ sort
```

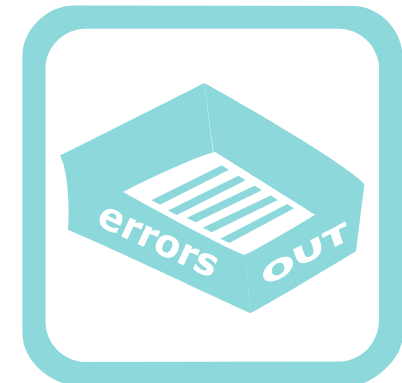
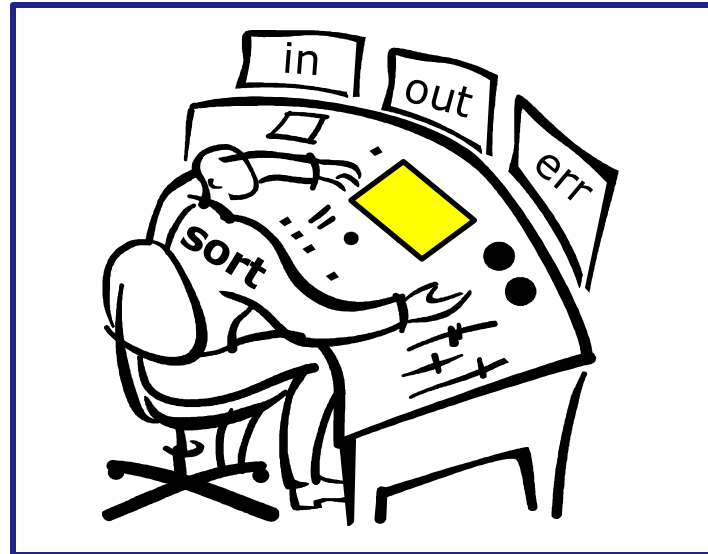
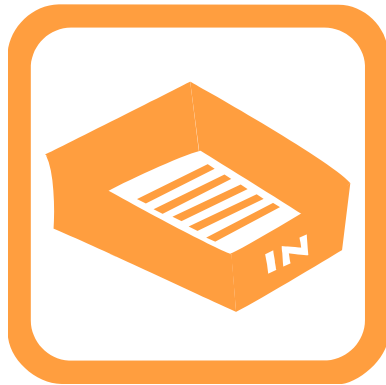

You (the sort process) check your instruction window and see that no options or arguments were passed to you from the shell to handle. You know (given your internal DNA code) that with no arguments you must look for lines to sort in your in tray, so you reach in to grab the first line to sort.

```
/home/cis90/simben $ sort
```

```
kayla  
sky  
bella  
benji  
charlie
```

*charlie benji bella sky kayla*

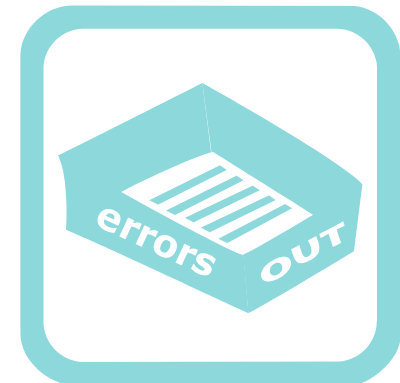
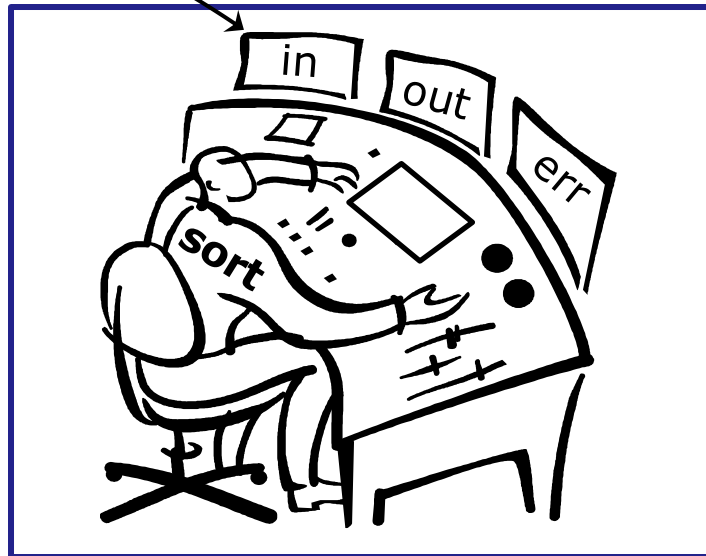

You work hard and fast. Each time you reach into the in tray there is another line! They just magically keep appearing into your in tray. You have no idea where they are coming from.



```
/home/cis90/simben $ sort
```

```
kayla  
sky  
bella  
benji  
charlie
```



EOF

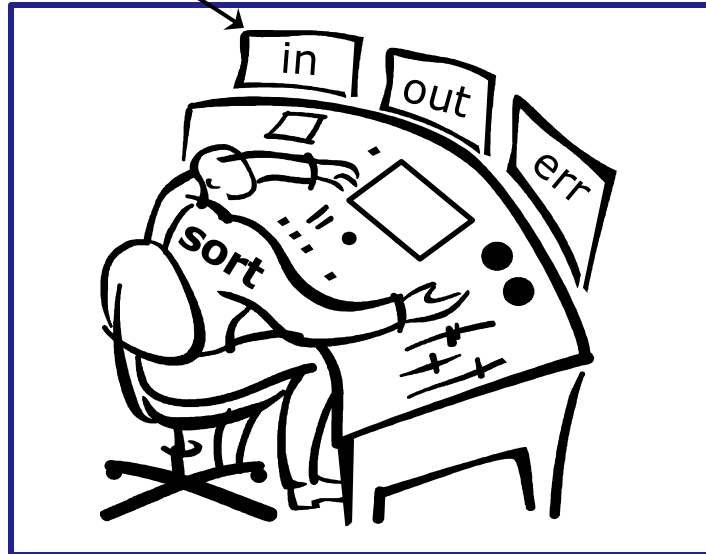

Then suddenly, when you reach for the next line, you find an EOF. You know (your internal DNA code) that this EOF means no more lines coming. You must sort what you have collected so far and place them, in order, into your out tray.

bella  
benji  
charlie  
kayla  
sky  
/home/cis90/simben \$

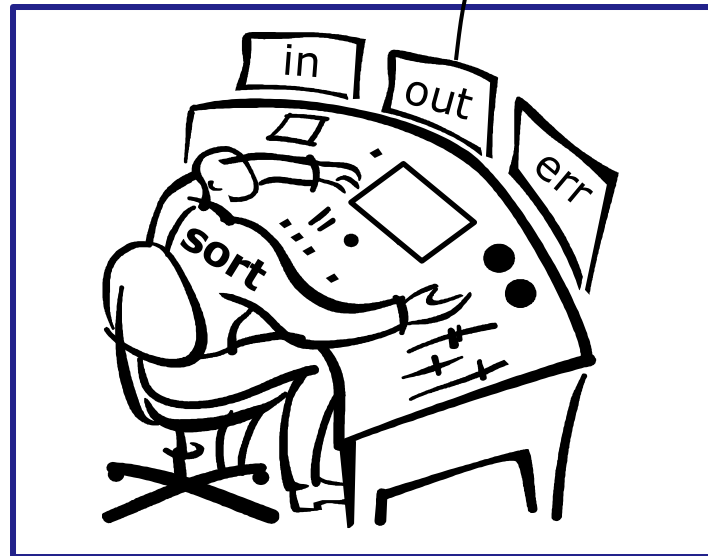
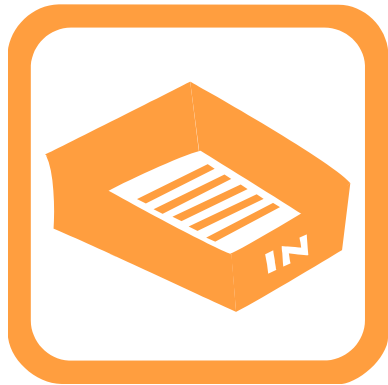

sky kayla charlie benji bella

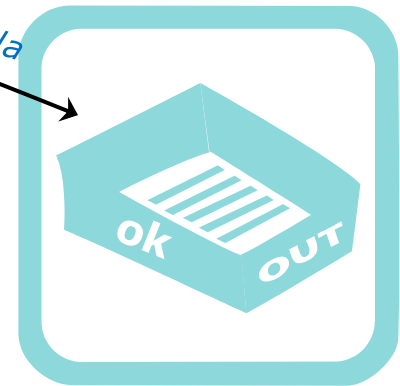

As fast as you can, you sort them, and place them in order in your out tray. They keep getting removed magically from the out tray. You have no idea where they go after that. You are done.

# sort <bad filepath>

```
/home/cis90/simben $ sort bogus  
sort: open failed: bogus: No such file or directory  
/home/cis90/simben $
```

 *No such file*

## Activity

### sort command with bad argument

```
/home/cis90/simben $ sort bogus
sort: open failed: bogus: No such file or directory
/home/cis90/simben $
```

*The sort program will try and open the file it receives as an argument and print an error message if the file does not exist*

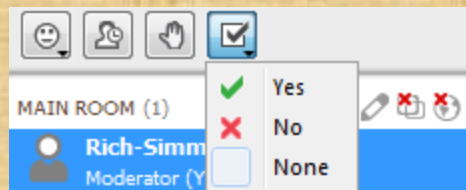

*Give me a green Yes check if you get the same results*

```
/home/cis90/simben $ sort bogus
```

### Shell Steps

- 1) Prompt
- 2) Parse
- 3) Search
- 4) Execute
- 5) Nap
- 6) Repeat

1. Prompt string is: `"/home/cis90/simben $ "`
2. Parsing results:
  - `command = sort`
  - no options
  - `1 argument = bogus`
  - no redirection
3. Search user's path and locate the sort program in `/bin`
4. Sort command loaded into memory and execution begins

```
/home/cis90/simben $ sort bogus
```

**Shell Steps**

- 1) Prompt
- 2) Parse
- 3) Search
- 4) Execute
- 5) Nap
- 6) Repeat

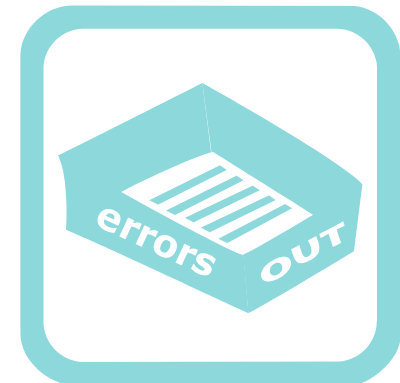
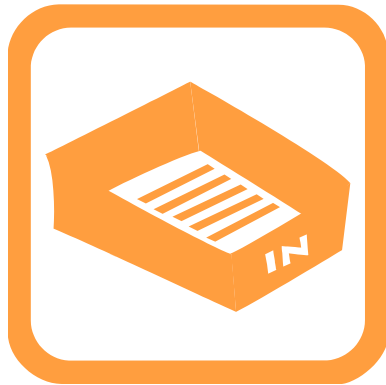

You check the instruction window and notice the shell passed you one argument: "bogus". You know (given your internal DNA code) that you must contact the kernel and request this file be opened.



```
/home/cis90/simben $ sort bogus  
sort: open failed: bogus: No such file or directory
```

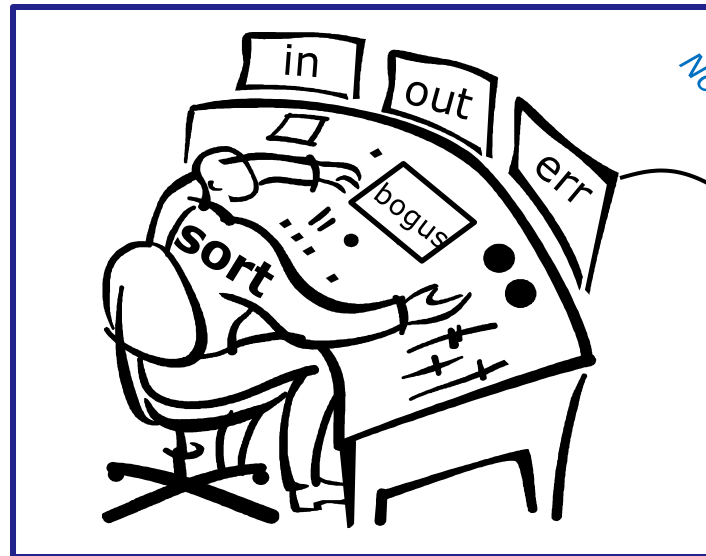
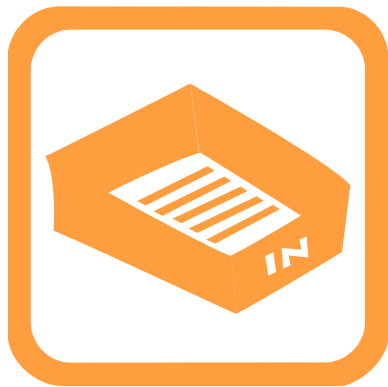

sort: open failed: bogus:  
No such file or directory

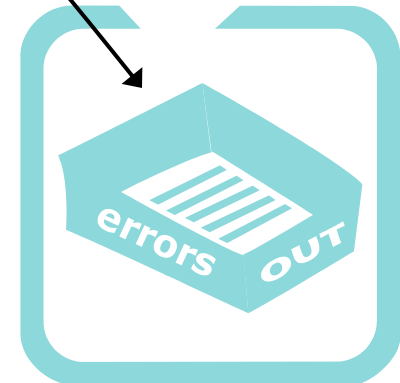

However the kernel tells you the file does not exist.  
You place an error message in the out tray for errors.  
You are done.



# Bringing it home

# File Descriptors

# Input and Output

## File Descriptors

Every process is given three open files upon its execution. These open files are inherited from the shell.

### **stdin**

Standard Input (0)

*defaults to the user's terminal keyboard*

### **stdout**

Standard Output (1)

*defaults to the user's terminal screen*

### **stderr**

Standard Error (2)

*defaults to the user's terminal screen*

*Ok, lets make the visualization a little more realistic*

The in and out trays are really the three open file descriptors inherited from the shell:  
**stdin (0)**, **stdout (1)** and **stderr (2)**.

**stdin (0)**



**stdout (1)**



**stderr (2)**



# Input and Output File Descriptors

*Now let's start to show the file descriptors as plumbing. They are "bent" because the running process can't see what they are attached to.*

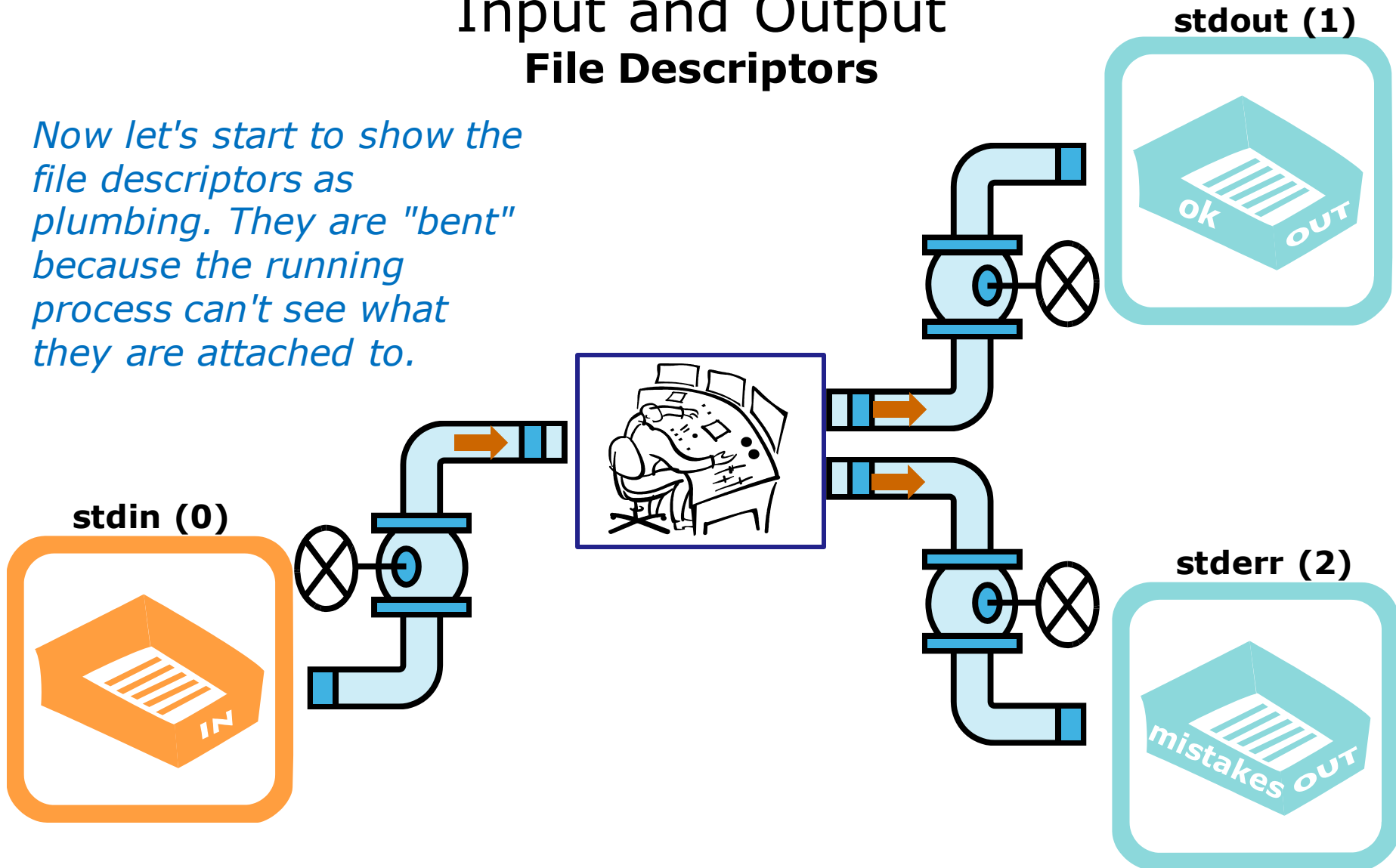

# Input and Output Loaded Process

Let's replace the little worker with a box. This box represents the **program** that has been loaded into memory and is now executing as a **process**.

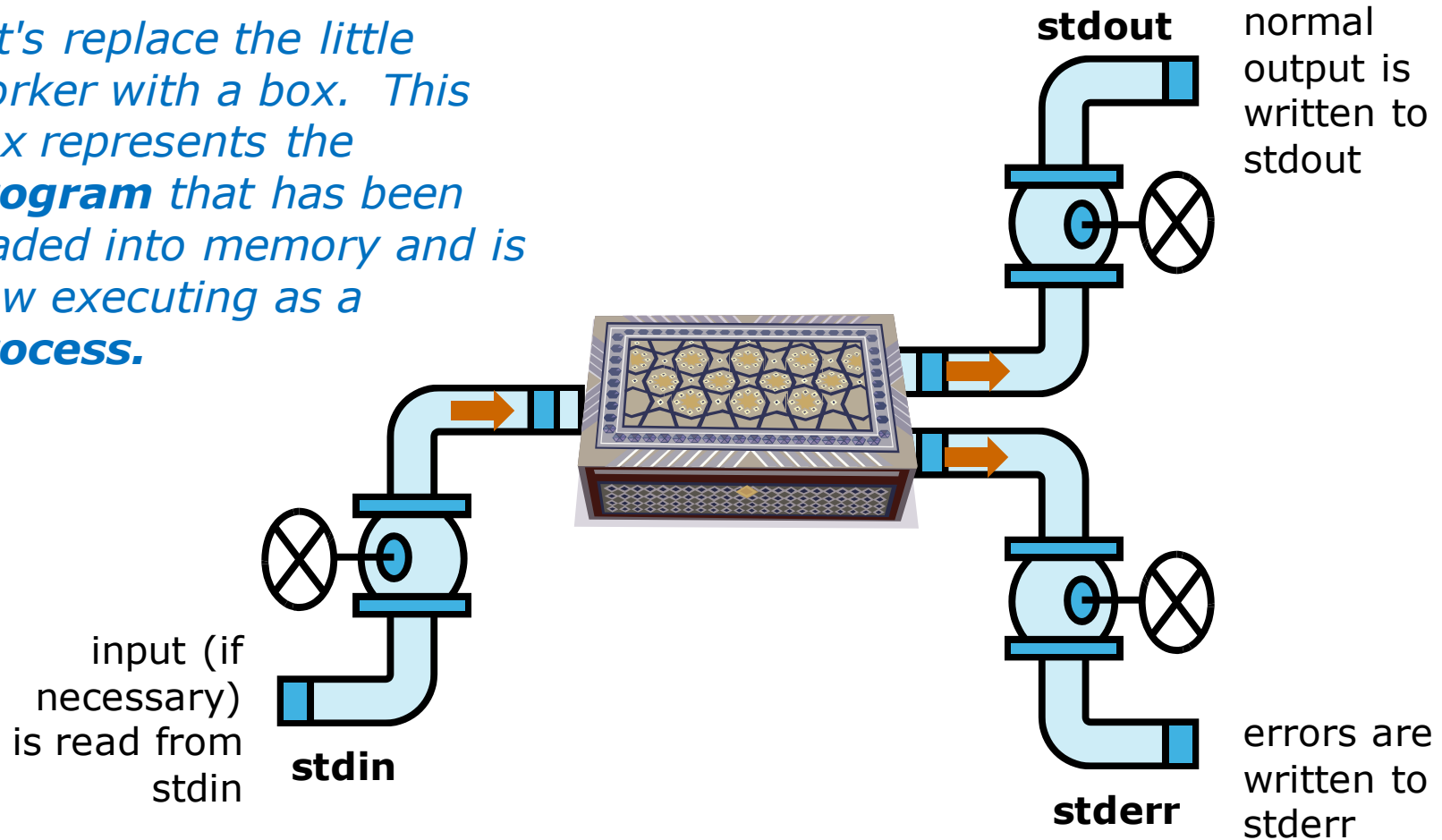



# Input and Output

## Default I/O devices

By default is attached to the user's terminal device (screen)

*Finally, lets show the default devices the plumbing is attached to.*

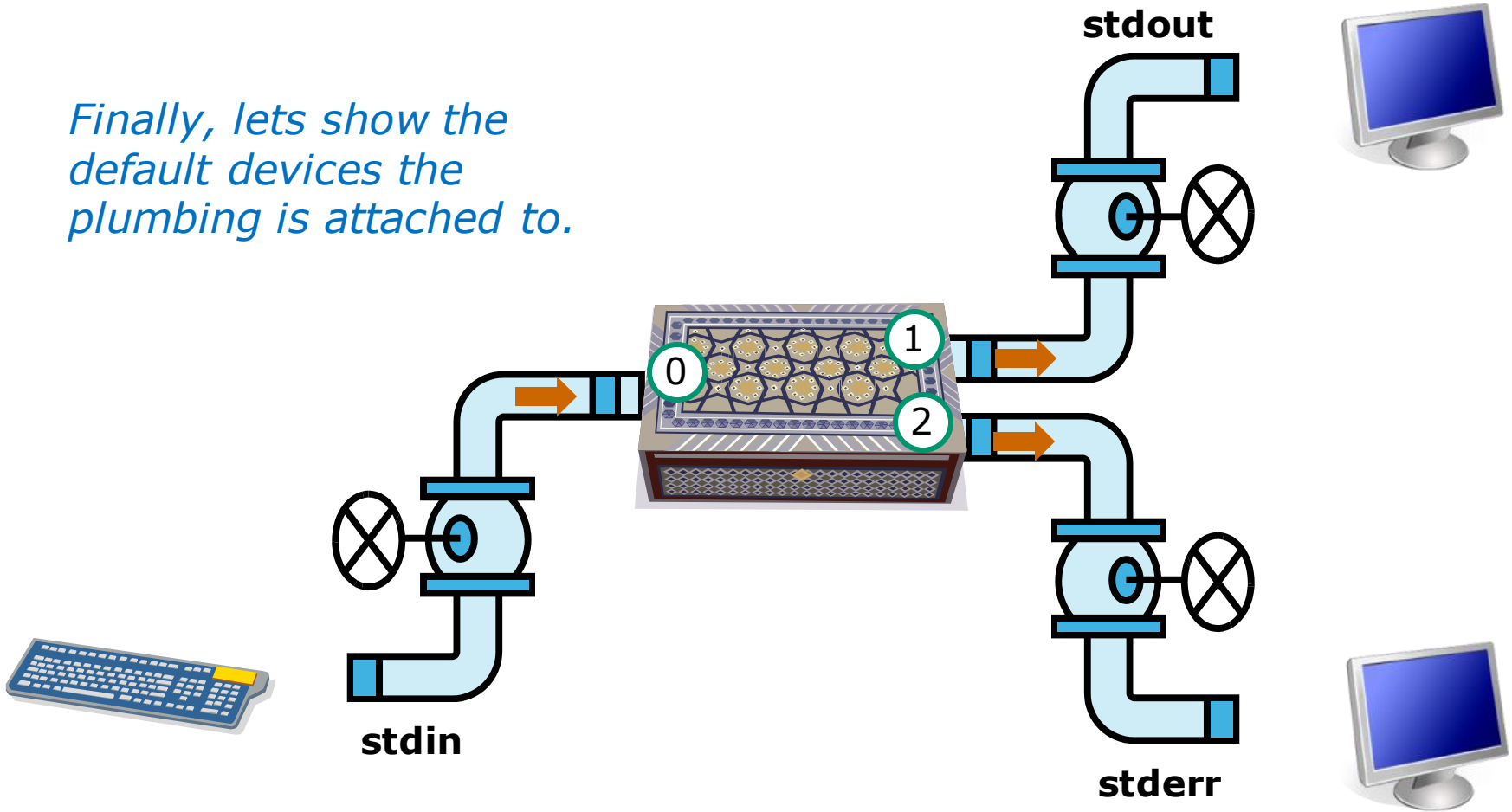

By default is attached to the user's terminal device (keyboard)

By default is attached to the user's terminal device (screen)

# The sort example again with no arguments

```
[simmsben@opus ~]$ sort
star
benji
duke
homer
benji
duke
homer
star
[simmsben@opus ~]$
```



Options: NA  
Args: NA

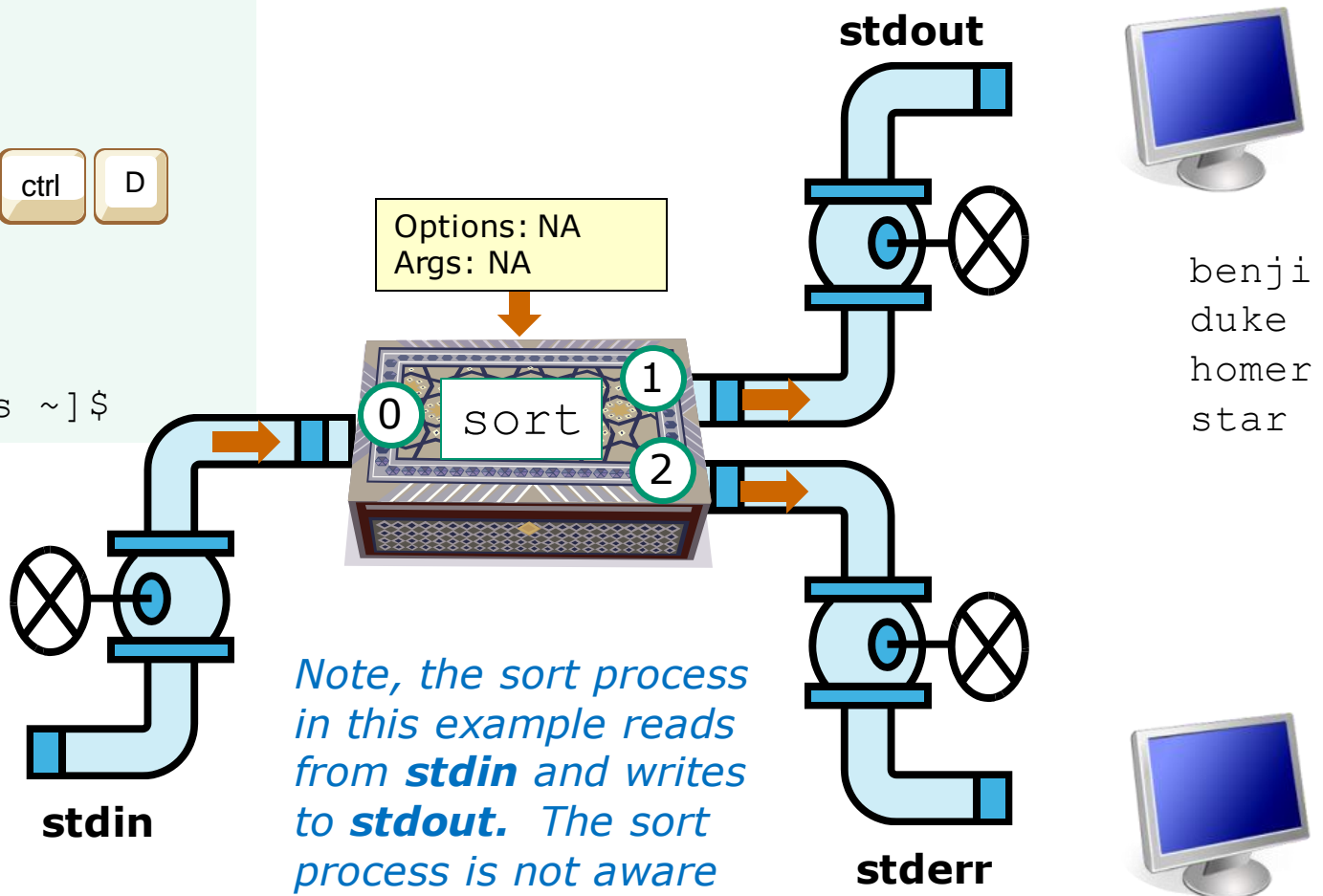

*Note, the sort process in this example reads from **stdin** and writes to **stdout**. The sort process is not aware what **stdin** or **stdout** are attached to*

star  
benji  
duke  
homer

benji  
duke  
homer  
star



# File Redirection

Life would be **BORING** if **stdin** was always attached to the terminal (keyboard), and **stdout** and **stderr** to the terminal (screen)!

*It would be much more **EXCITING** if we could change where input comes from or where output goes!*

*defaults to the user's terminal screen*

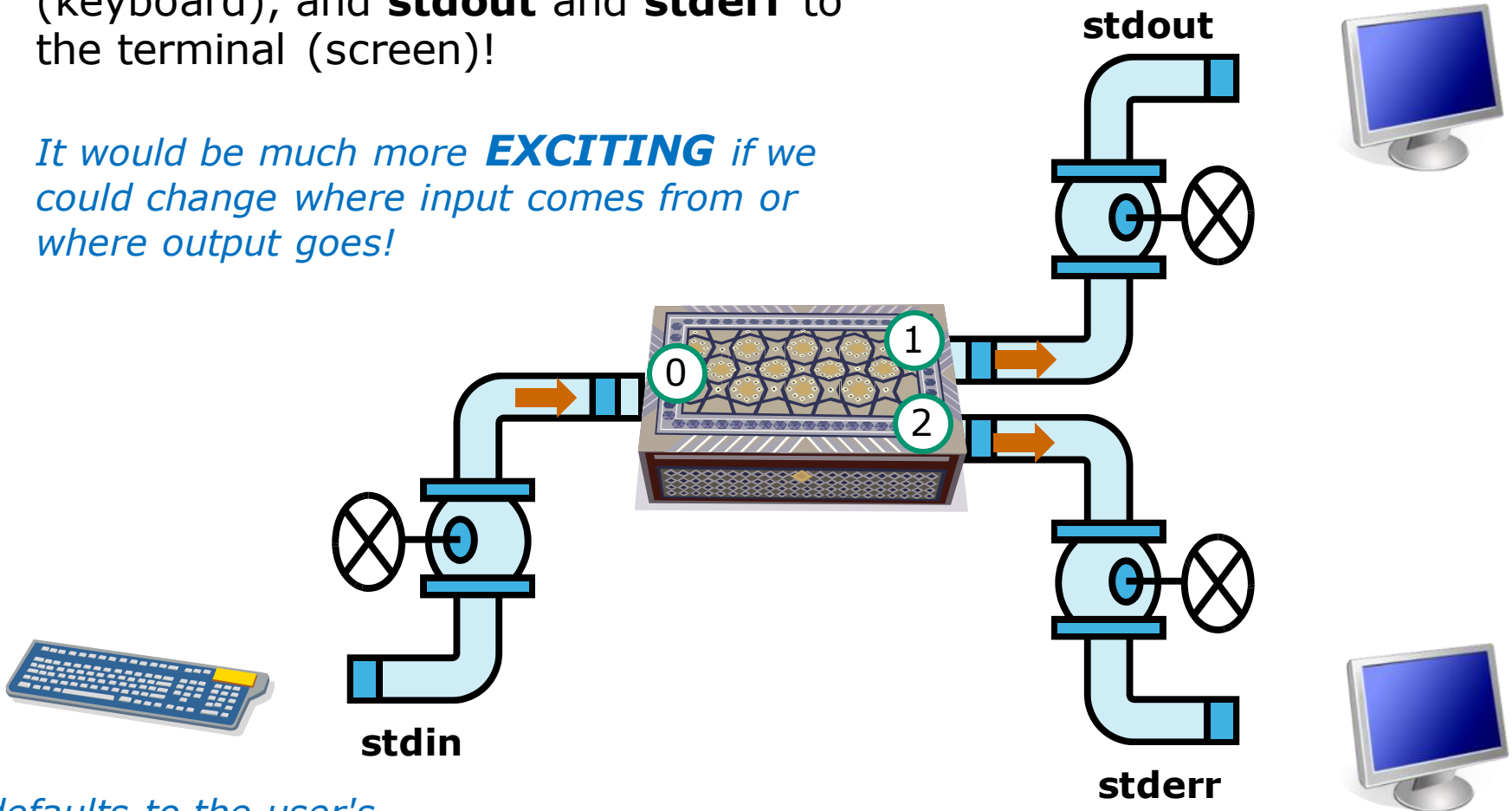

*defaults to the user's terminal keyboard*

*defaults to the user's terminal screen*

# Input and Output

## File Redirection

*Let's look at the  
sort example again*

```
/home/cis90/simben $ sort  
duke  
benji  
star  
homer  
benji  
duke  
homer  
star  
/home/cis90/simben $
```



The diagram illustrates the effect of pressing Ctrl+D on the output of the `sort` command. It shows two buttons labeled "ctrl" and "D" with a blue dotted arrow pointing from them to the word "homer" in the output list. Below the buttons is the text "End of File".

# Input and Output

## File Redirection



Read from **stdin**

```
/home/cis90/simben $ sort
```

```
duke  
benji  
star  
homer
```

*The sort program reads lines from **stdin** (attached to keyboard)*



"End of File"

Written to **stdout**



```
benji  
duke  
homer  
star
```

*After the EOF it performs the sort and writes to **stdout** (attached to terminal)*

```
/home/cis90/simben $
```

# sort command (no arguments)

```

/home/cis90/simben $ sort
duke
benji
star
homer
benji
duke
homer
star
/home/cis90/simben $
    
```



/dev/pts/0



benji  
duke  
homer  
star

/dev/pts/0



duke  
benji  
star  
homer

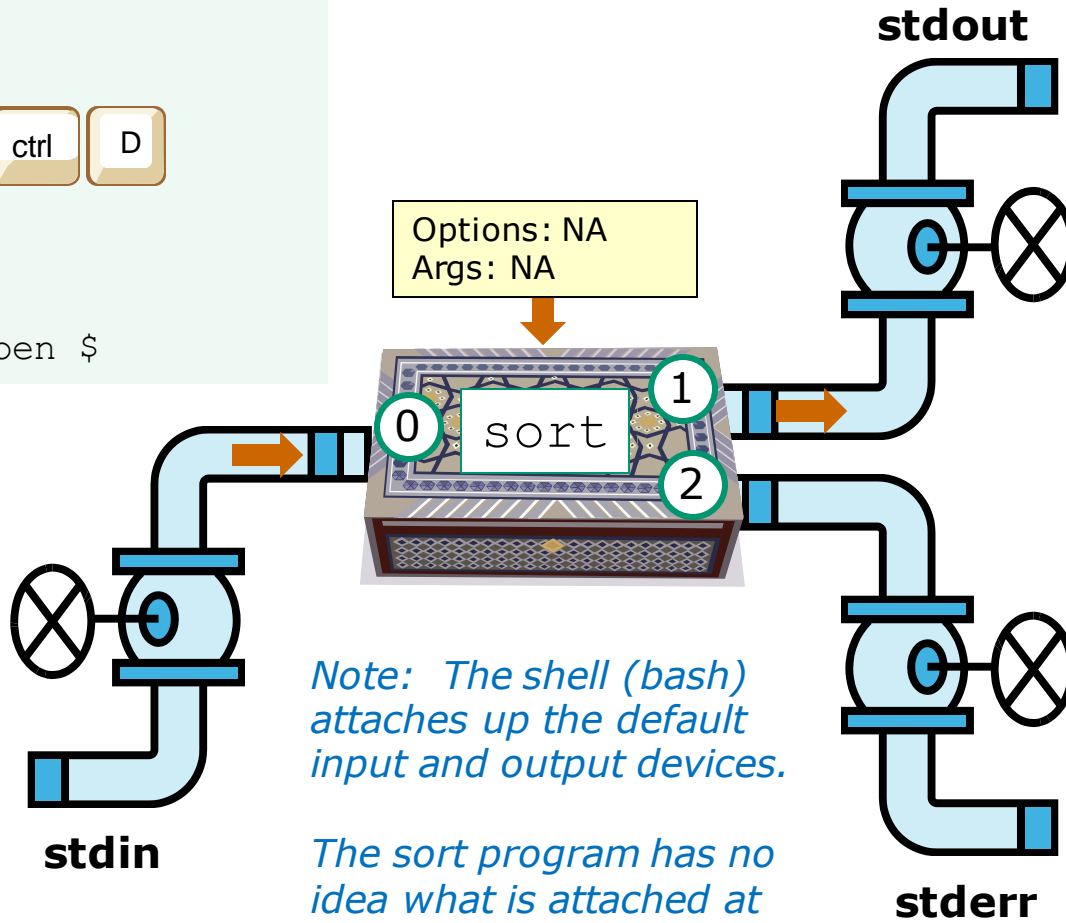

*Note: The shell (bash) attaches up the default input and output devices.*

*The sort program has no idea what is attached at the end of the pipes.*



# Activity

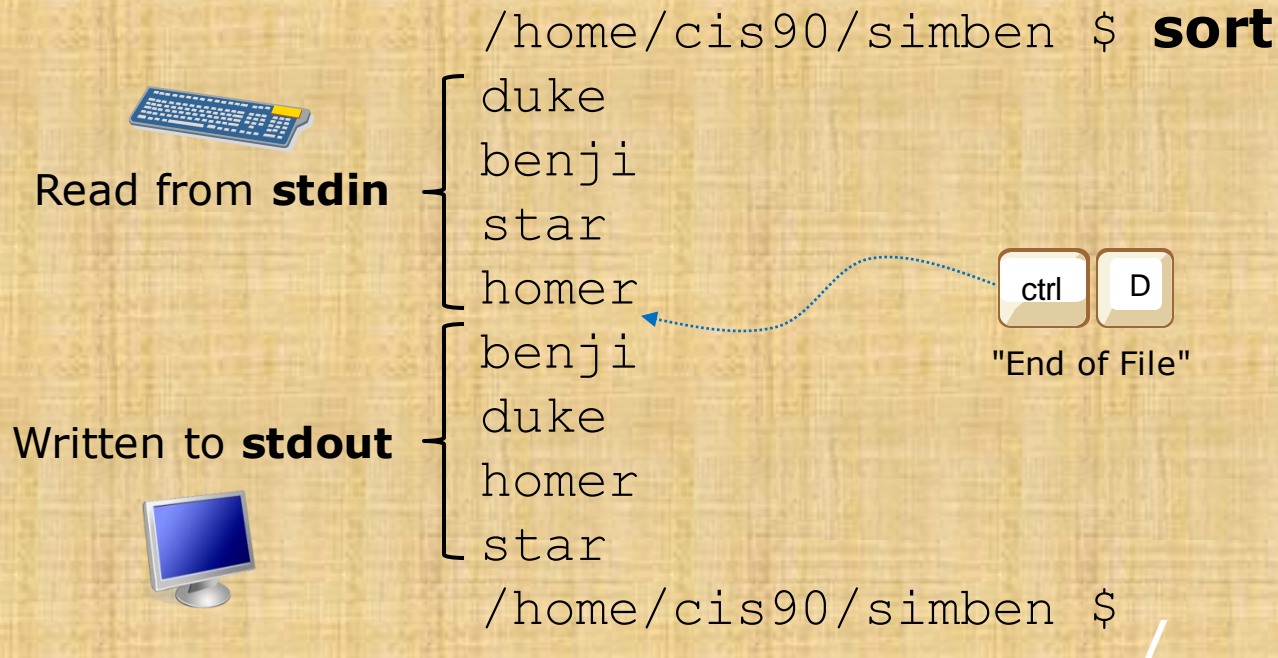

When YOU do this. What specific device is stdin and stdout attached to? Write your answer in the chat window.

# Input and Output

## File Redirection

The input and output of a program can be **redirected** from and to other files using `<`, `>`, `2>` and `>>`:

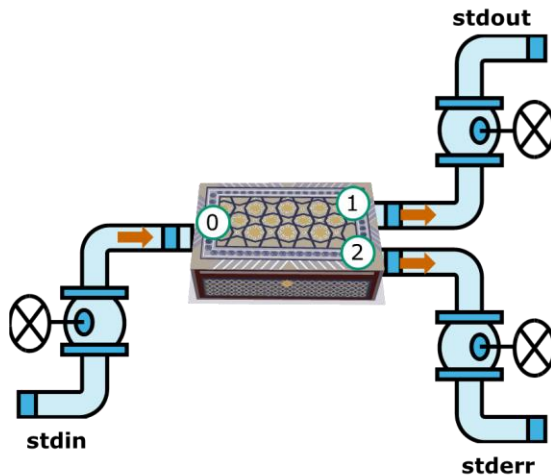

~~0~~< **filename**

To redirect **stdin** (either `0<` or just `<`)

~~1~~> **filename**

To redirect **stdout** (either `1>` or just `>`)

**2>** **filename**

To redirect **stderr**

**>>** **filename**

To redirect **stdout** and append

# No arguments, redirecting stdout

sort just reads from **stdin**  
and writes to **stdout**

**stdout** has been  
redirected to the file  
*dogsinorder*

```
[simmsben@opus ~]$ sort > dogsinorder
```

**duke**

**benji**

**star**

**homer**



If the file *dogsinorder* does not exist, it is  
created. If it does exist it is emptied!

```
[simmsben@opus ~]$ cat dogsinorder
```

benji

duke

homer

star

```
[simmsben@opus ~]$
```

# No arguments, redirecting stdout

```
$ sort > dogsinorder
```

```
duke  
benji  
star  
homer  
$
```



dogsinorder

```
$ cat dogsinorder  
benji  
duke  
homer  
star
```

/dev/pts/0



duke  
benji  
star  
homer

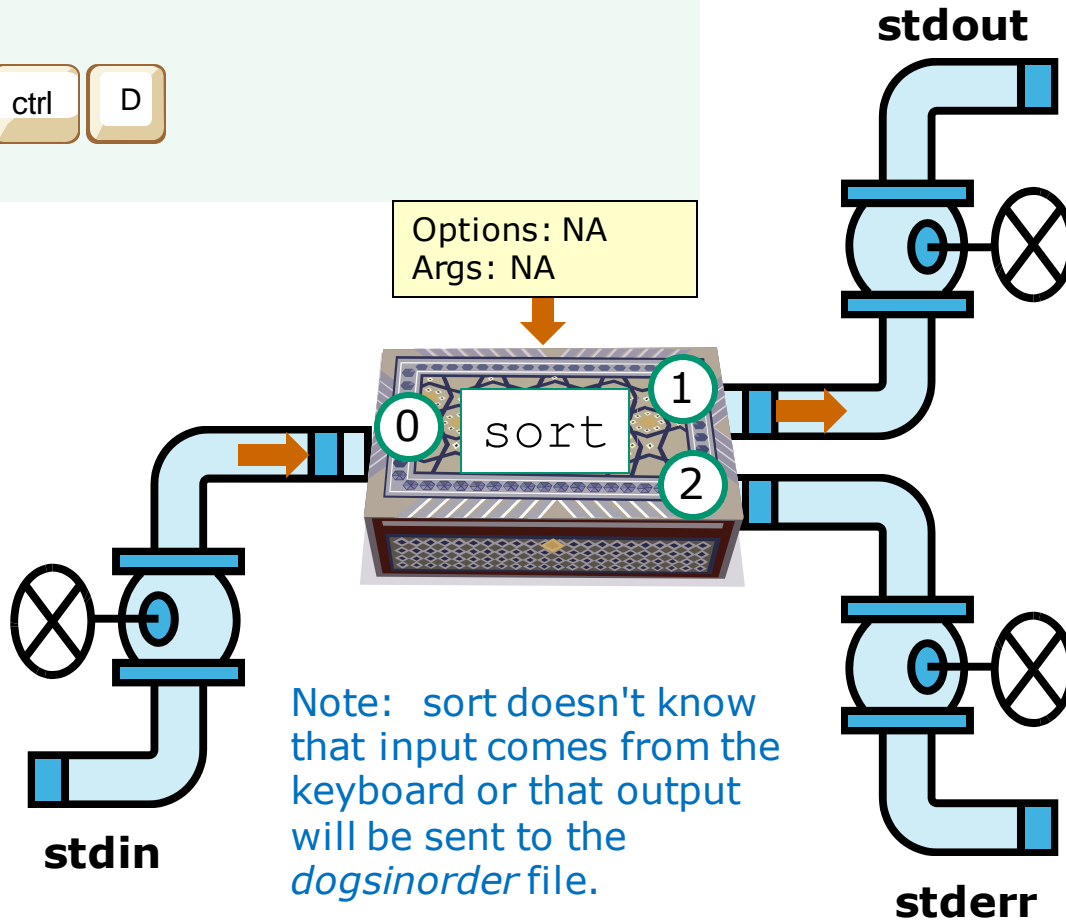

Note: `sort` doesn't know that input comes from the keyboard or that output will be sent to the `dogsinorder` file.

It just reads from **stdin** and writes to **stdout**.

## Now you try it

```
[simmsben@opus ~]$ sort > dogsinorder
```

**duke**

**benji**

**star**

**homer**



```
[simmsben@opus ~]$ cat dogsinorder
```

benji

duke

homer

star

```
[simmsben@opus ~]$
```

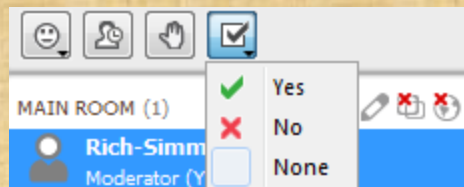

*Give me a green Yes check  
if you get the same results*

# No arguments, redirecting stdin and stdout

```
[simben@opus ~]$ cat names
```

```
duke
```

```
benji
```

```
star
```

```
homer
```

input is redirected to come  
from the file *names*

output is redirected to the  
file *dogsinorder*

```
[simben@opus ~]$ sort < names > dogsinorder
```

```
[simben@opus ~]$ cat dogsinorder
```

```
benji
```

```
duke
```

```
homer
```

```
star
```

```
[simben@opus ~]$
```

Note: The bash shell handles the  
command line parsing and redirection.  
The sort command has no idea what  
*stdin* or *stdout* are attached to.



# No arguments, redirecting stdin and stdout

```
$ sort < names > dogsinorder
```

Note: `sort` doesn't know about the `names` or `dogsorder` files. It just reads from **stdin** and writes to **stdout**.

```
$ cat names
duke
benji
star
homer
```



names

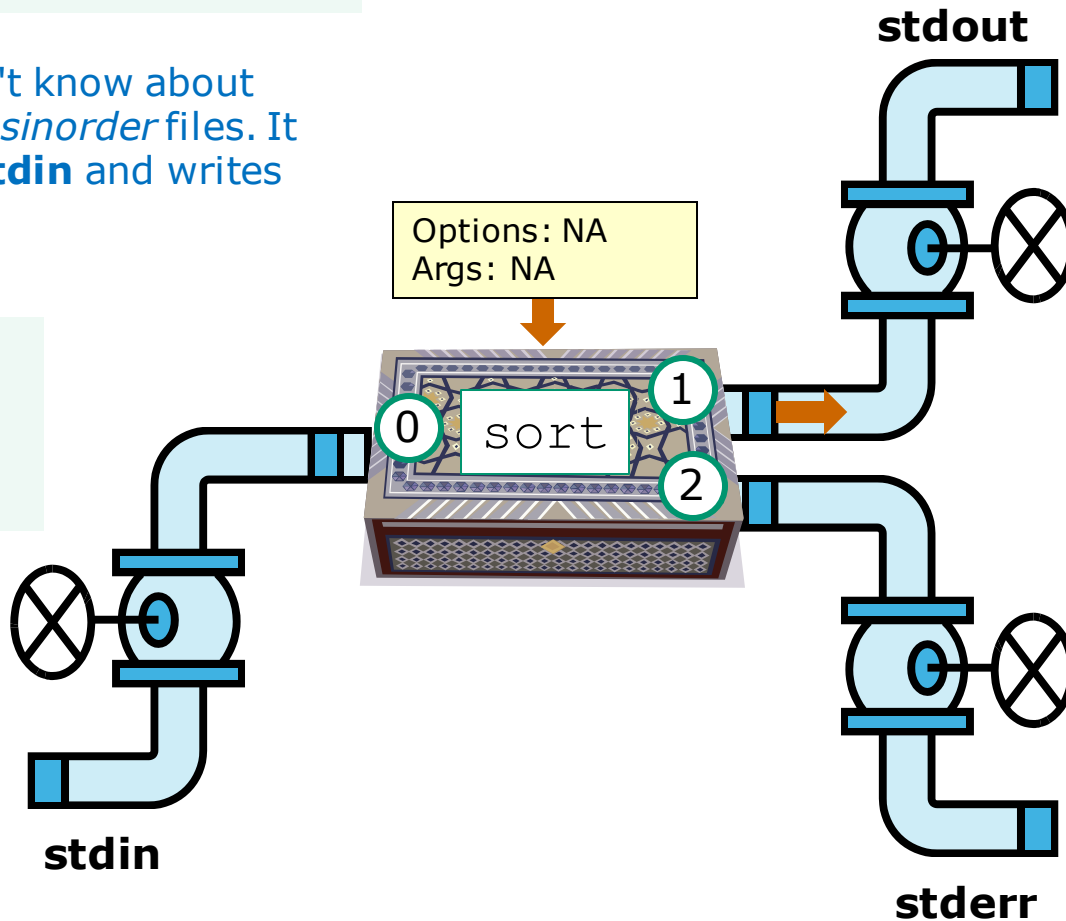

dogsorder

```
$ cat dogsorder
benji
duke
homer
star
```

In this example, `sort` is getting its input from **stdin**, which has been redirected to the `names` file



## Now you try it

```
[simben@opus ~]$ cat names
```

```
duke
```

```
benji
```

```
star
```

```
homer
```

```
[simben@opus ~]$ sort < names > dogsinorder
```

```
[simben@opus ~]$ cat dogsinorder
```

```
benji
```

```
duke
```

```
homer
```

```
star
```

```
[simben@opus ~]$
```

Does the **sort** program know that its input came from the *names* file or its output went to from the *dogsorder* file?

Put your answer in the chat window.

# One argument, redirecting stdout

The *names* file is parsed as an **argument** and is passed to the sort process to handle.

Output written to **stdout** is redirected to the file *dogsinorder*.

The shell, not the sort program, opens the *dogsinorder* file.

```
[simben@opus ~]$ sort names > dogsinorder
```

```
[simben@opus ~]$ cat dogsinorder
```

```
benji
```

```
duke
```

```
homer
```

```
star
```

```
[simben@opus ~]$
```

The sort program, not the shell, opens and reads directly from the *names* file.

Корисне для наступного вікторини!

## One argument, redirecting stdout

```
$ sort names > dogsinorder
```

Note: `sort` knows about the `names` file but doesn't know about the `dogsinorder` file. It reads directly from the file `names` and writes to **stdout**.

Корисне для наступного вікторини!

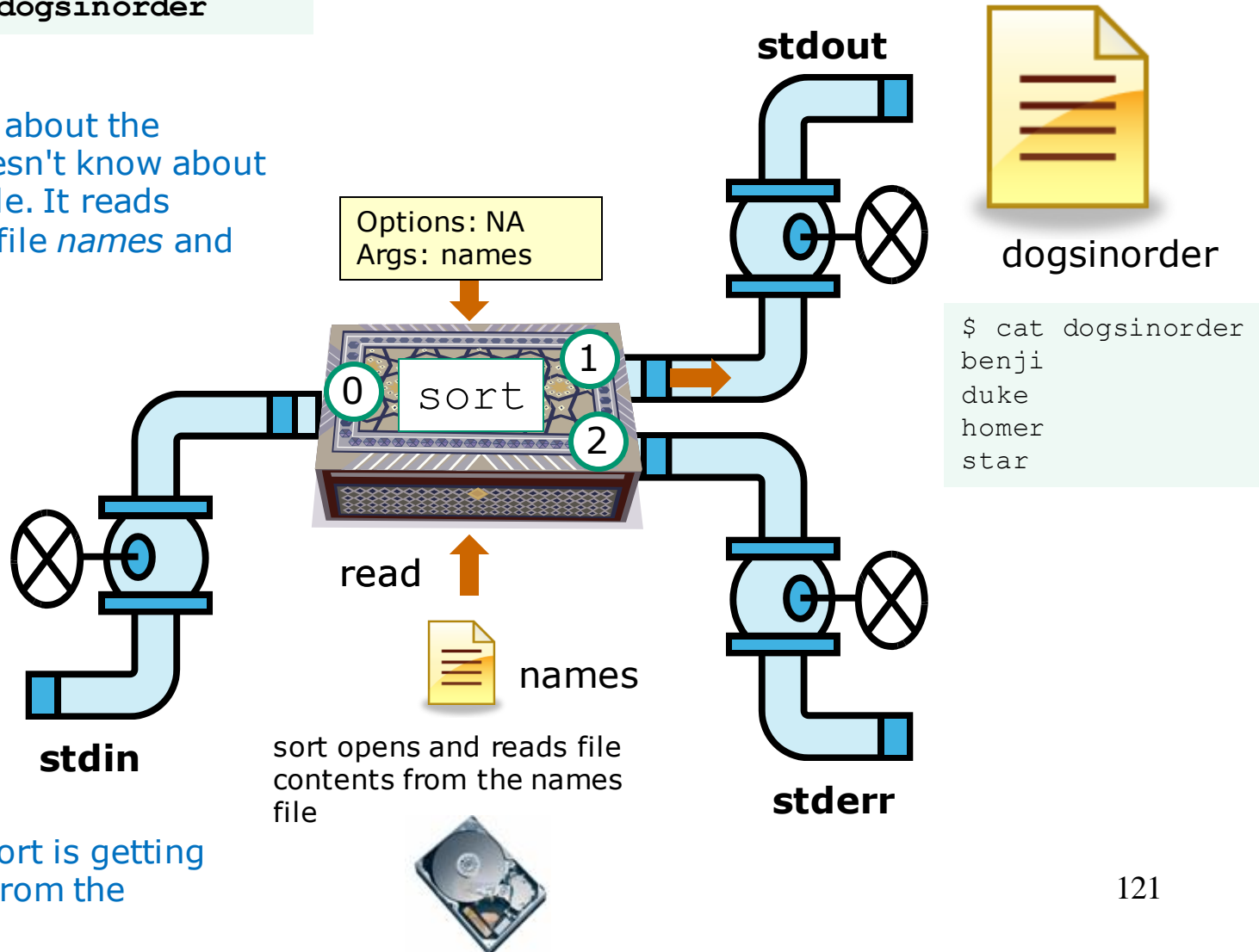

In this example, `sort` is getting its input directly from the `names` file

## Now you try it

```
[simben@opus ~]$ sort names > dogsinorder  
[simben@opus ~]$ cat dogsinorder  
benji  
duke  
homer  
star  
[simben@opus ~]$
```

Корисне для  
наступного  
вікторина!

Does the **sort** program know that its  
input came from the *names* file?

Put your answer in the chat window

yes

# One option, one argument, redirecting stdout

specifying an option  
(for reverse order)

*names* is parsed as an  
argument and passed to the  
sort command

sort writes to **stdout**, which is  
redirected to the file *dogsিনorder*

```
[simben@opus ~]$ sort -r names > dogsিনorder
```

```
[simben@opus ~]$ cat dogsিনorder
```

```
star
```

```
homer
```

```
duke
```

```
benji
```

```
[simben@opus ~]$
```

This **-r** option does the sort in  
reverse order

The shell opens the *dogsিনorder*  
file. The sort process is not aware  
that output is redirected there.

# One option, one argument, redirecting stdout

```
$ sort -r names > dogsinorder
```

Note: `sort` does know about the `names` file and the `-r` option however it doesn't know about the `dogsinorder` file.

`sort` reads directly from `names` and writes to **stdout**.

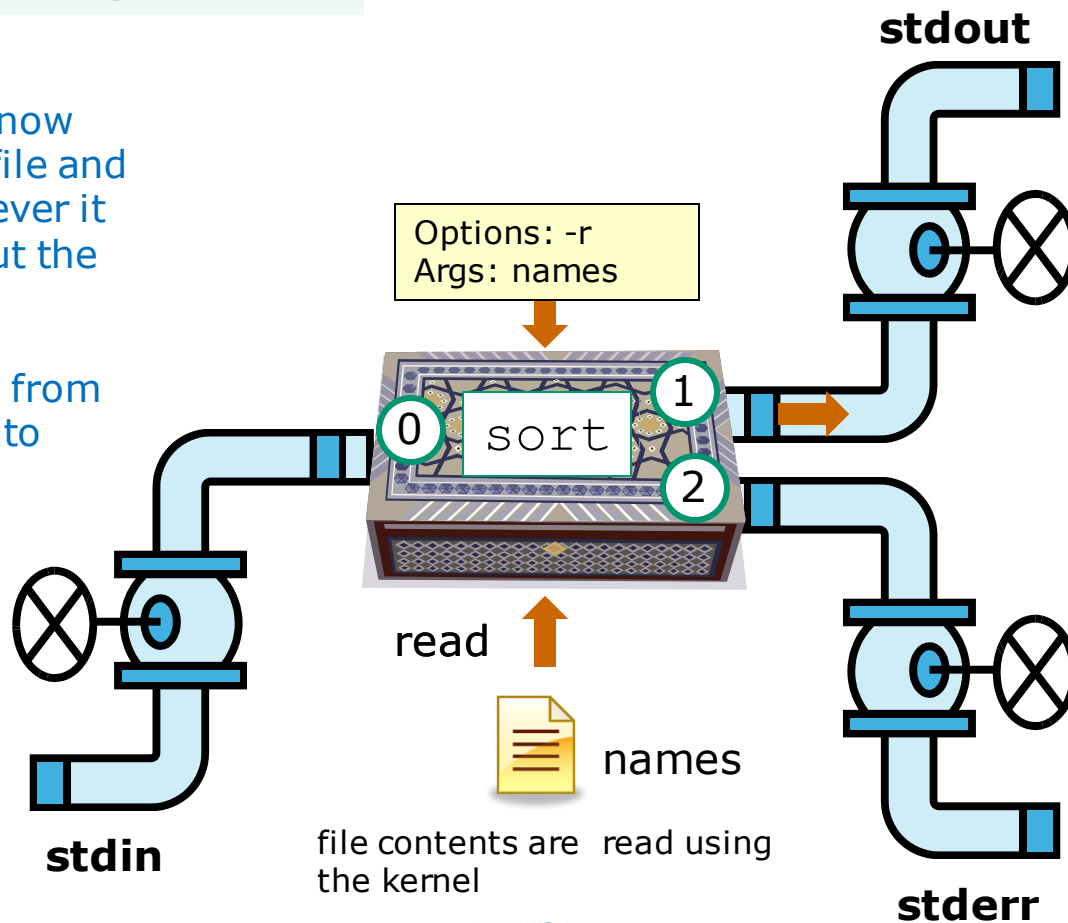

```
$ cat dogsinorder
star
homer
duke
benji
```

*In this example, `sort` is getting its input directly from the `names` file*

## Now you try it

```
/home/cis90/simben $ sort -r names > dogsinorder  
/home/cis90/simben $ cat dogsinorder  
star  
homer  
duke  
benji  
/home/cis90/simben $
```

Корисне для  
наступного  
вікторини!

Does the **sort** program know that its output is going to the *dogsinorder* file?

Put your answer in the chat window

no



# Append vs Overwrite

## > (overwrites) vs >> (appends)

```
[simben@opus ~]$ echo "Hello World" > message
```

```
[simben@opus ~]$ cat message
```

```
Hello World
```

```
[simben@opus ~]$ echo "Hello Universe" >> message
```

```
[simben@opus ~]$ cat message
```

```
Hello World
```

```
Hello Universe
```

*>> does not empty  
file, just appends to  
the end*

```
[simben@opus ~]$ echo "Oops" > message
```

```
[simben@opus ~]$ cat message
```

```
Oops
```

*> empties then  
**overwrites** anything  
already in the file!*

```
[simben@opus ~]$ > message
```

```
[simben@opus ~]$ cat message
```

```
[simben@opus ~]$
```

## 2> (overwrites) vs 2>> (appends)

```
/home/cis90/simben $ ls bogus 2> errors
/home/cis90/simben $ cat errors
ls: cannot access bogus: No such file or directory
/home/cis90/simben $ ls crud 2> errors
/home/cis90/simben $ cat errors
ls: cannot access crud: No such file or directory
```

*2> causes the file errors to be emptied and overwritten with error output*

```
/home/cis90/simben $ ls bogus 2> errors
/home/cis90/simben $ ls crud 2>> errors
/home/cis90/simben $ cat errors
ls: cannot access bogus: No such file or directory
ls: cannot access crud: No such file or directory
/home/cis90/simben $
```

*2>> appends error output to the errors file*



# More redirection examples

## Example 1

Input from stdin, redirecting stdout to another terminal device

/dev/pts/0

```
[simben@opus ~]$ cat names
duke
benji
star
homer
[simben@opus ~]$
[simben@opus ~]$ tty
/dev/pts/0
[simben@opus ~]$ sort names > /dev/pts/1
[simben@opus ~]$
```

*Note, everything in UNIX is a file so we can even redirect to another terminal*

/dev/pts/1

```
[simben@opus ~]$ tty
/dev/pts/1
[simben@opus ~]$ benji
duke
homer
star
```

# Example 1 diagram

Input from stdin, redirecting stdout to another terminal device

```
$ sort names > /dev/pts/1
```

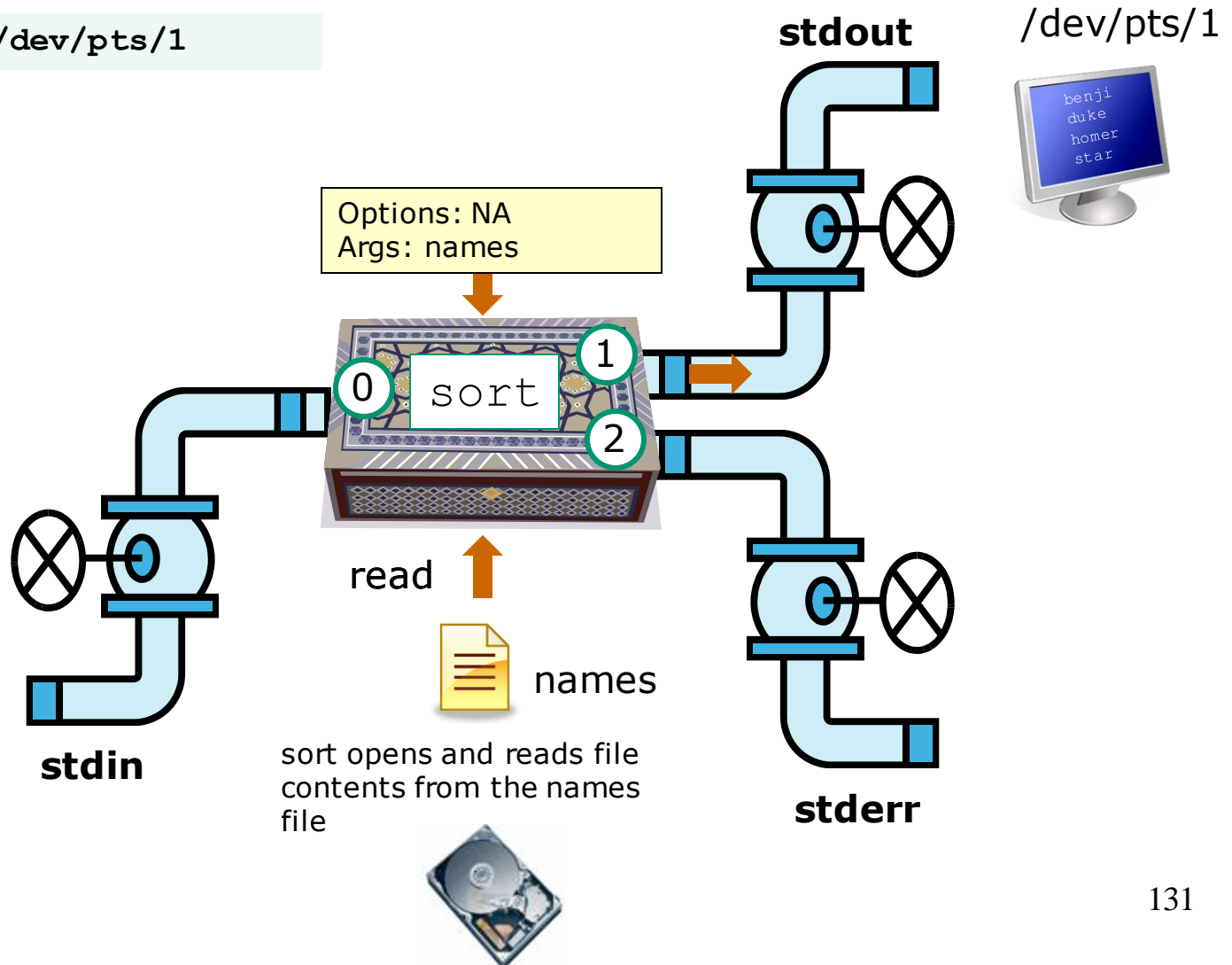

## Example 2

Input from the command line, redirecting stdout to file

```
/home/cis90/simben $ echo "Hello World" > message  
/home/cis90/simben $ cat message  
Hello World  
/home/cis90/simben $
```



## Example 2 diagram

Input from the command line, redirecting stdout to file

```
$ echo "Hello World" > message
```

Note: In this example echo does not use **stdin**. It gets its input from the command line and writes to **stdout** which is redirected to the file *message*.

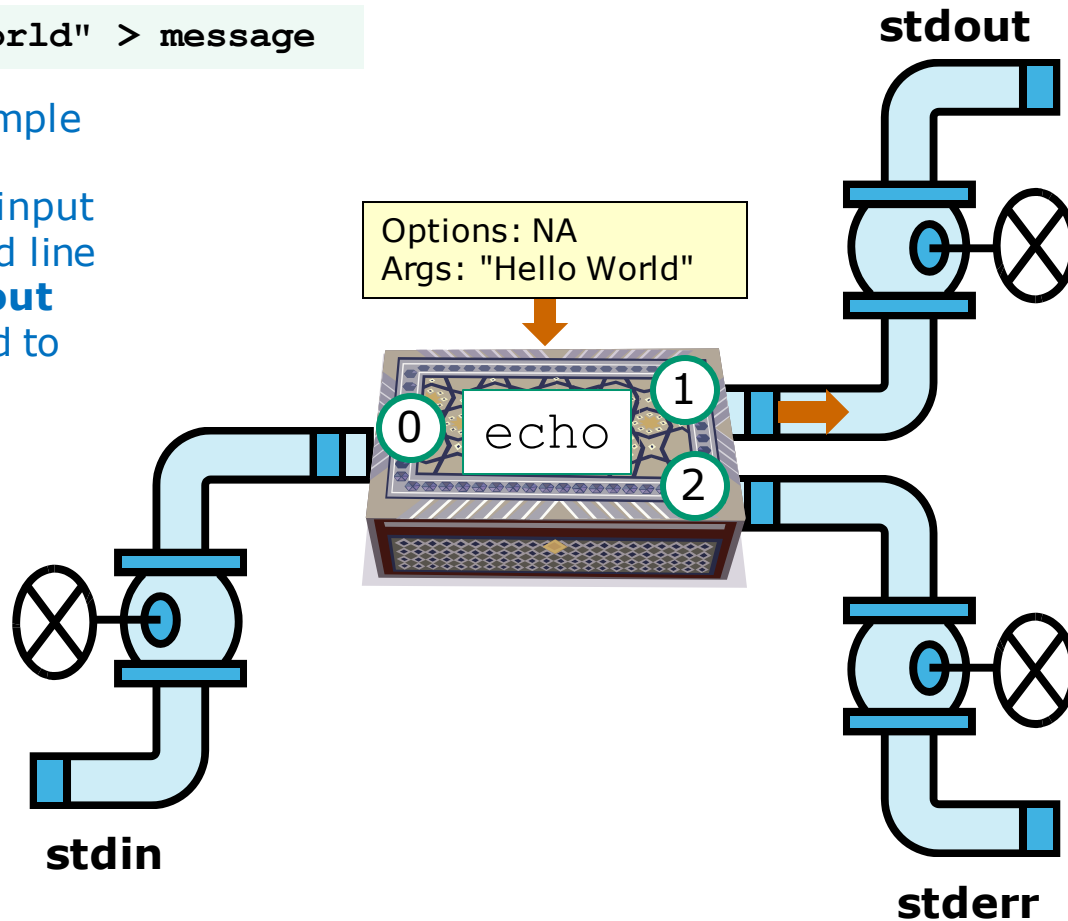

message

```
$ cat message
Hello World
```

## Example 3

Input from command line and OS, redirecting stdout and stderr

```
[simben@opus ~]$ ls -lR > snapshot
ls: ./Hidden: Permission denied
[simben@opus ~]$ head -10 snapshot
.:
total 296
-rw-rw-r-- 1 simben cis90      51 Sep 24 17:13 1993
-rw-r--r-- 21 guest90 cis90 10576 Jul 20 2001 bigfile
drwxr-x--- 2 simben cis90  4096 Oct  8 09:05 bin
drwx--x--- 4 simben cis90  4096 Oct  8 09:00 class
-rw----- 1 simben cis90   484 Sep 24 18:13 dead.letter
drwxrwxr-x 2 simben cis90  4096 Oct  8 09:05 docs
-rw-rw-r-- 1 simben cis90    22 Oct 20 10:51 dogsinorder
drwx----- 2 simben cis90  4096 Oct 16 09:17 edits
[simben@opus ~]$
```

*Note: errors are written to **stderr**, which is attached by default to the terminal*

```
[simben@opus ~]$ ls -lR > snapshot 2> errors
[simben@opus ~]$ cat errors
ls: ./Hidden: Permission denied
[simben@opus ~]$
```

*> redirects **stdout** to file named snapshot*

*2> redirects **stderr** to file named errors*



## Example 4

### Redirecting stdin, stdout and stderr

```
[simben@opus ~]$ echo 2+2 > math
```

```
[simben@opus ~]$ bc < math
```

```
4
```

bc reads input from **stdin** (redirected to *math*) and writes to **stdout** (attached to the terminal)

```
[simben@opus ~]$ echo 4/0 >> math
```

```
[simben@opus ~]$ cat math
```

```
2+2
```

```
4/0
```

```
[simben@opus ~]$ bc < math
```

```
4
```

```
Runtime error (func=(main), adr=5): Divide by zero
```

bc reads inputs from **stdin** (redirected to *math*), writes to **stdout** (attached to the terminal) and writes errors to **stderr** (attached to the terminal)

```
[simben@opus ~]$ bc < math > answers 2> errors
```

```
[simben@opus ~]$ cat answers
```

```
4
```

bc reads inputs from **stdin** (redirected to *math*), writes to **stdout** (redirected to *answers*) and writes errors to **stderr** (redirected to *errors*)

```
[simben@opus ~]$ cat errors
```

```
Runtime error (func=(main), adr=5): Divide by zero
```

# Example 4 diagram

## Redirecting stdin, stdout and stderr

```
$ bc < math > answers 2> errors
```

Note: The shell sends no options or arguments from the command line to **bc**. Input is redirected to come from the *math* file, output is redirected to the *answers* file and errors are redirected to the *errors* file.

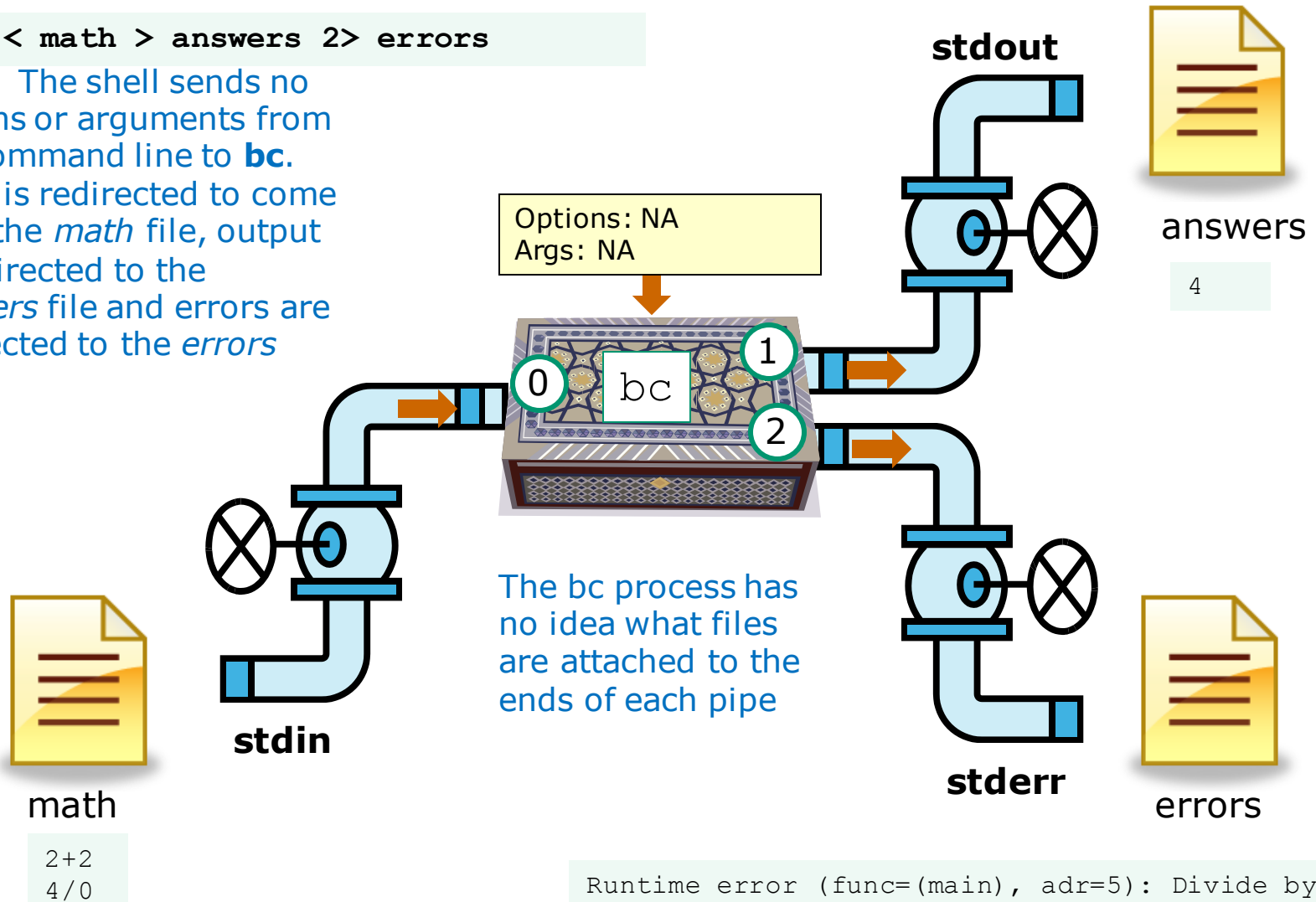



# The bit bucket `/dev/null`

## /dev/null = "bit bucket"

*A bit bucket is very handy. You can throw stuff into it and never see it again!*

<http://www.adrianmouat.com/bit-bucket/>

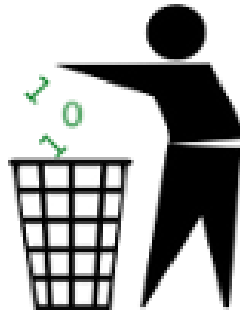

<http://didyouknowarchive.com/?p=1755>

*It's like having your own black hole to discard those unwanted bits into!*



# /dev/null = "bit bucket"

*Whatever you redirect to /dev/null/  
is gone forever*

```
/home/cis90/simben $ echo Clean up your room! > orders
/home/cis90/simben $ cat orders
Clean up your room!
/home/cis90/simben $
```

```
/home/cis90/simben $ echo Clean up your room! > /dev/null
/home/cis90/simben $ cat /dev/null
/home/cis90/simben $
```

Корисне для  
наступного  
вікторини!

*This is how you redirect output to the bit bucket*

# Pipelines

# Input and Output Pipelines

Commands may be chained together in such a way that the **stdout** of one command is "piped" into the **stdin** of a second process.

## Filters

A program that both reads from **stdin** and writes to **stdout**.

## Tees

A filter program that reads **stdin** and writes it to **stdout and the file** specified as the argument.

# Input and Output Pipelines

Note:

Use **redirection** operators (<, >, >>, 2>) to redirect input and output from and to **files**

Use the **pipe** operator (|) to pipe output from one **command** for use as input to another **command**

# Pipeline Example

```
[simben@opus ~]$ cat letter | wc -l  
28
```

*Counting the lines in the letter file*

# Counting lines in the letter file

```
$ cat letter | wc -l
```

*cat writes to **stdout** which is piped to **stdin** for **wc**!*

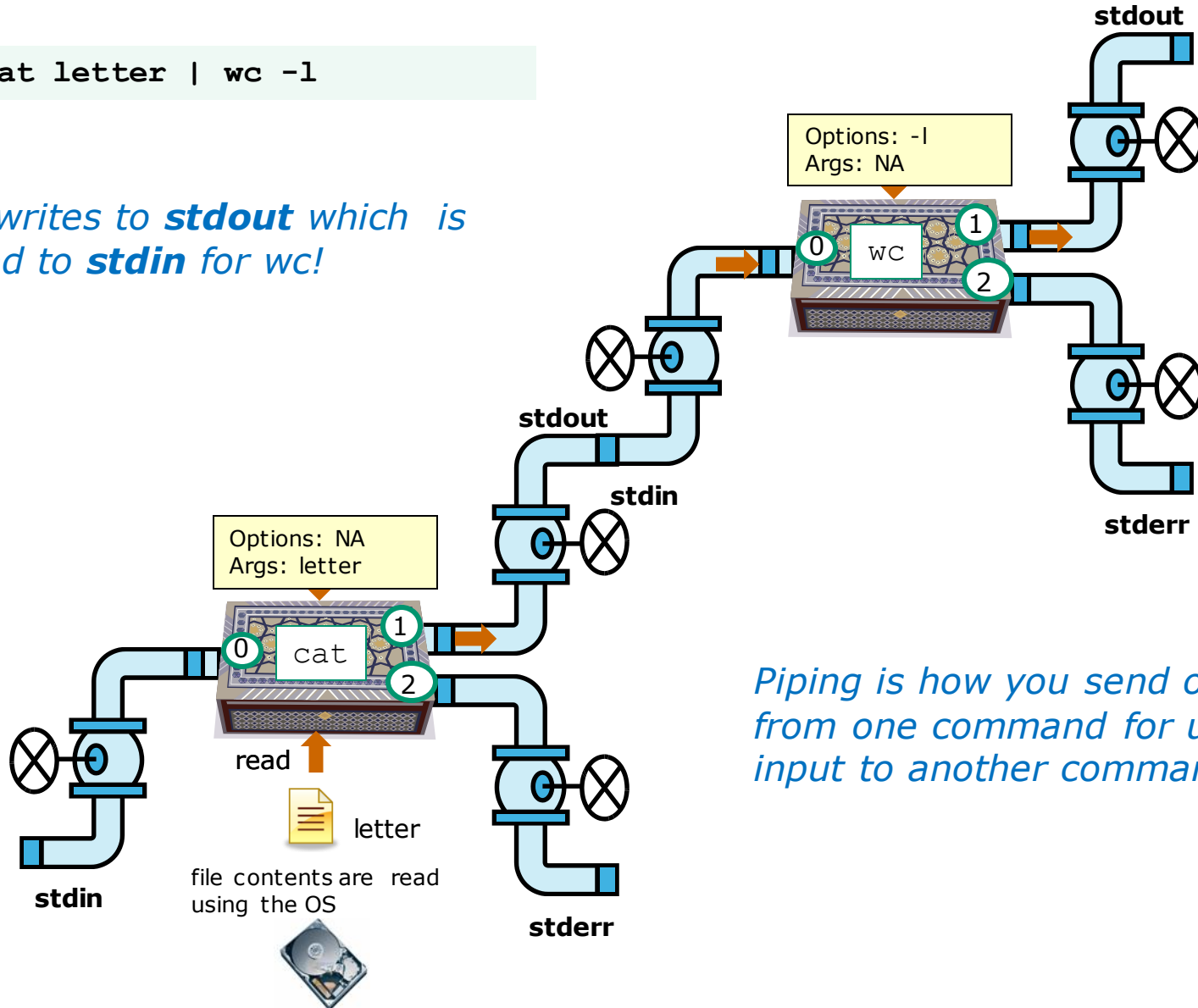

*Piping is how you send output from one command for use as input to another command*

## You try it

### *Counting the lines in the letter file*

```
/home/cis90/simben $ cat letter | wc -l  
28
```

### *Counting the number of Shakespeare poems*

```
/home/cis90/simben $ ls poems/Shakespeare/ | wc -l  
15
```



# find command

# Find Command

## Basic syntax

(see man page for the rest of the story)

```
find <start-directory> -name <filename>  
                -type <filetype>  
                -user <username>  
                -group <groupname>  
                -exec <command> {} \;
```

Use the **find** command to find files by their name, type, owner, group (or other attributes) and optionally run a command on each of the files found.

The find command is **recursive** by default. It will start finding files at the <start directory> and includes all files and sub-directories in that branch of the file tree.

# find command with no options or arguments

The **find** command by itself lists all files in the current directory and recursively down into any sub-directories.

```
[simben@opus poems] $ find
```

```
.
./Blake
./Blake/tiger
./Blake/jerusalem
./Shakespeare
./Shakespeare/sonnet1
./Shakespeare/sonnet2
./Shakespeare/sonnet3
./Shakespeare/sonnet4
./Shakespeare/sonnet5
./Shakespeare/sonnet7
./Shakespeare/sonnet9
./Shakespeare/sonnet10
./Shakespeare/sonnet15
./Shakespeare/sonnet17
./Shakespeare/sonnet26
./Shakespeare/sonnet35
./Shakespeare/sonnet11
./Shakespeare/sonnet6
./Yeats
./Yeats/whitebirds
./Yeats/mooncat
./Yeats/old
./Anon
./Anon/ant
./Anon/nursery
./Anon/twister
```

*Because no start directory was specified the find command will start listing files in the current directory (poems)*

*note: reduced font size so it will fit on this slide*

```
[simben@opus poems] $
```

## find command - the starting directory

*One or more starting directories in the file tree can be specified as an argument to the find command which will list recursively all files and sub-folders from that directory and down*

```
/home/cis90/simben $ find /etc/ssh
/etc/ssh
/etc/ssh/ssh_config
/etc/ssh/ssh_host_dsa_key.pub
/etc/ssh/moduli
/etc/ssh/ssh_host_key
/etc/ssh/ssh_host_dsa_key
/etc/ssh/ssh_host_rsa_key.pub
/etc/ssh/ssh_host_rsa_key
/etc/ssh/ssh_host_key.pub
/etc/ssh/sshd_config
/home/cis90/simben $
```

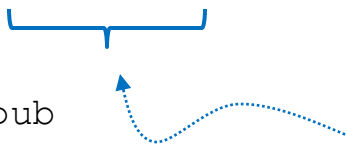

*this find command will start listing files from the /etc/ssh directory*

## The find command -name option

*Since no starting directory was specified find will start in the current directory (simben90's home directory.*

*Directs the find command to only look for files whose names start with "sonnet"*

```

/home/cis90/simben $ find -name 'sonnet*'
find: `./Hidden': Permission denied
./poems/Shakespeare/sonnet10
./poems/Shakespeare/sonnet15
./poems/Shakespeare/sonnet26
./poems/Shakespeare/sonnet3
./poems/Shakespeare/sonnet35
./poems/Shakespeare/sonnet6
./poems/Shakespeare/sonnet2
./poems/Shakespeare/sonnet4
./poems/Shakespeare/sonnet1
./poems/Shakespeare/sonnet11
./poems/Shakespeare/sonnet7
./poems/Shakespeare/sonnet5
./poems/Shakespeare/sonnet9
./poems/Shakespeare/sonnet17
/home/cis90/simben $
  
```

## All those permission errors

*An error is printed for every directory lacking read permission!*

*Where to start finding files*

*only include files  
named sonnet6*

```
[simben@opus ~]$ find /home/cis90 -name sonnet6
```

```
find: /home/cis90/guest/.ssh: Permission denied
find: /home/cis90/guest/Hidden: Permission denied
/home/cis90/guest/Poems/Shakespeare/sonnet6
find: /home/cis90/guest/.gnupg: Permission denied
find: /home/cis90/guest/.gnome2: Permission denied
find: /home/cis90/guest/.gnome2_private: Permission denied
find: /home/cis90/guest/.gconf: Permission denied
find: /home/cis90/guest/.gconfd: Permission denied
find: /home/cis90/simben/Hidden: Permission denied
```

*Yuck! How  
annoying is this?*

*<snipped>*

```
find: /home/cis90/wichemic/class: Permission denied
find: /home/cis90/crivejoh/Hidden: Permission denied
/home/cis90/crivejoh/poems/Shakespeare/sonnet6
[simben@opus ~]$
```



## Redirecting find errors to the bit bucket

*redirecting stderr  
to the "bit bucket"*

```
[simben@opus ~]$ find /home/cis90 -name sonnet6 2> /dev/null
/home/cis90/guest/Poems/Shakespeare/sonnet6
/home/cis90/simben/poems/Shakespeare/sonnet6
/home/cis90/stanlcha/poems/Shakespeare/sonnet6
/home/cis90/seatocol/poems/Shakespeare/sonnet6
/home/cis90/wrigholi/poems/Shakespeare/sonnet6
/home/cis90/dymesdia/poems/Shakespeare/sonnet6
/home/cis90/lyonsrob/poems/Shakespeare/sonnet6
/home/cis90/ybarrser/poems/Shakespeare/sonnet6
/home/cis90/ybarrser/poems/Sonnets/sonnet6
/home/cis90/valdemar/poems/Shakespeare/sonnet6
/home/cis90/elliokat/poems/Shakespeare/sonnet6
/home/cis90/jessuwes/poems/Shakespeare/sonnet6
/home/cis90/luisjus/poems/Shakespeare/sonnet6
/home/cis90/meyerjas/poems/Shakespeare/sonnet6
/home/cis90/bergelyl/sonnet6
/home/cis90/bergelyl/poems/Shakespeare/sonnet6
/home/cis90/gardnnic/poems/Shakespeare/sonnet6
/home/cis90/mohanchi/poems/Shakespeare/sonnet6
/home/cis90/whitfbob/poems/Shakespeare/sonnet6
/home/cis90/crivejoh/poems/Shakespeare/sonnet6
[simben@opus ~]$
```

*Ahhh ... much better!*

*All the annoying error  
messages are redirected  
to the bit bucket*

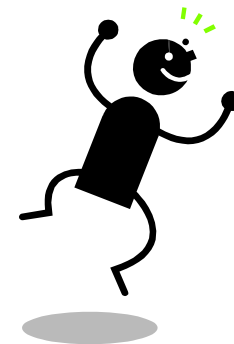

*This is why we want a  
bit bucket*



# find command examples

*start finding in /  
(the top of the file tree)*

```
[simben@opus ~]$ find / 2> /dev/null | wc -l  
154033
```

*redirect permission  
errors into the bit  
bucket (discard them)*

*pipe the output of the **find**  
command as input to the **wc**  
command*

***wc** counts the number of  
lines read from stdin*

Корисне для  
наступного  
вікторини!

*Getting an approximate count of all the files on Opus and suppressing any permission errors*

# find command examples

*The directory to start finding files*

*Redirect errors written to stderr to the bit bucket*

```

/home/cis90/simben $ find /home -user root 2> /dev/null
/home
/home/cis175
/home/cis172
/home/cis172/computers.txt
/home/cis172/science.txt
/home/lost+found
/home/cis90/simben $

```

*The user that owns the files*

*Find all files in the /home directory that belong to the root user and discard any error messages*

# find command examples

*The directory to start finding files*

*Redirect errors to the bit bucket*

```

/home/cis90/simben $ find /home -type d -user milhom90 2> /dev/null
/home/turnin/cis90/milhom90
/home/cis90/milhom
/home/cis90/milhom/Hidden
/home/cis90/milhom/Lab2.0
/home/cis90/milhom/Miscellaneous
/home/cis90/milhom/bin
/home/cis90/milhom/Poems
/home/cis90/milhom/Poems/Shakespeare
/home/cis90/milhom/Poems/Yeats
/home/cis90/milhom/Poems/Blake
/home/cis90/milhom/Lab2.1
/home/cis90/milhom/Lab2.1/filename
/home/cis90/milhom/cis90_html
/home/cis90/milhom/cis90_html/images
/home/cis90/milhom/cis90_html/css
/home/cis90/milhom/.ssh
/home/cis90/simben $

```

*Only find type d files (directories)*      *Only those that belong to milhom90*

*Find all directories starting in /home that belong to milhom90 and suppress permission errors*

# find command examples

*start from "here"* →

```
[simben@opus ~]$ find . -type d -name '[BSYA]*'
find: ./Hidden: Permission denied
./poems/Blake
./poems/Shakespeare
./poems/Yeats
./poems/Anon
[simben@opus ~]$
```

*specifies directories only*

*specifies only files whose names start with a B, S, Y or A*

*Find all directories, starting from the current directory that start with a capital B, S, Y or A.*

# find command examples

*No start directory specified so start in current directory*

*file type "f" (regular)*

*file names contain the letter "k"*

*The command to run on each file found*

```
/home/cis90/simben $ find -type f -name '*k*' -exec file {} \;
find: `./Hidden': Permission denied
./edits/spellk: ASCII English text
./kshrc: ASCII text
./docs/MarkTwain: ASCII English text
./ssh/known_hosts: ASCII text, with very long lines
/home/cis90/simben $
```

**-exec file {} \;**

*The {} are replaced by filenames as they are found*

*Escape the ; so it will be passed to the find command*

*Run the file command on all regular files found starting in the current directory whose names contain the letter "k"*

## Now you try it

*start from "here"*

*specifies only  
files whose  
names contain  
"town"*

```
[simben@opus ~]$ find . -name '*town*'  
find: ./Hidden: Permission denied  
./edits/small_town  
./edits/better_town  
[simben@opus ~]$
```

*Find all files starting from your current location whose names contain "town"*



# Filter commands



A command is called a "**filter**" if it can read from *stdin* and write to *stdout*

**cat** - concatenate

**grep** - "Global Regular Expression Print"

**sort** - sort

**spell** - spelling correction

**wc** - word count

**tee** - split output

**cut** - cut fields from a line

*Filters enable building useful pipelines*



# grep command

# grep command

## Basic syntax

(see man page for the rest of the story)

**grep** *<options>* "search string" *<filenames...>*

**grep -R** *<options>* "search string" *<start-directory>*

Use the **grep** command to search the **contents** of files. Use the **-R** option to do a recursive search starting from a directory

Some other useful options:

- i (case insensitive)
- w (whole word)
- v (does not contain)
- n (show line number)
- color (uses color to show matches)

# grep for text string

*string to search for*    *files to search contents of*



```
[simben@opus poems]$ grep love Shakespeare/son*
Shakespeare/sonnet10:For shame deny that thou bear'st love to any,
Shakespeare/sonnet10:Shall hate be fairer lodg'd then gentle love?
Shakespeare/sonnet10:    Make thee another self for love of me,
Shakespeare/sonnet15:    And all in war with Time for love of you,
Shakespeare/sonnet26:Lord of my love, to whom in vassalage
Shakespeare/sonnet26:    Then may I dare to boast how I do love thee,
Shakespeare/sonnet3:Of his self-love, to stop posterity?
Shakespeare/sonnet3:Calls back the lovely April of her prime,
Shakespeare/sonnet4:Unthrifty loveliness, why dost thou spend
Shakespeare/sonnet5:The lovely gaze where every eye doth dwell
Shakespeare/sonnet9:    No love toward others in that bosom sits
```



*files that contain love*

*Looking for love in all the wrong places?*

*Find the word love in Shakespeare's sonnets*

# Now you try it

*The color option*

**grep --color love poems/Shakespeare/\***

```

simben90@oslab:~
/home/cis90/simben $ grep --color love poems/Shakespeare/*
poems/Shakespeare/sonnet10:For shame deny that thou bear'st love to any,
poems/Shakespeare/sonnet10:Shall hate be fairer lodg'd then gentle love?
poems/Shakespeare/sonnet10:      Make thee another self for love of me,
poems/Shakespeare/sonnet15:      And all in war with Time for love of you,
poems/Shakespeare/sonnet26:Lord of my love, to whom in vassalage
poems/Shakespeare/sonnet26:      Then may I dare to boast how I do love thee,
poems/Shakespeare/sonnet3:Of his self-love, to stop posterity?
poems/Shakespeare/sonnet3:Calls back the lovely April of her prime,
poems/Shakespeare/sonnet4:Unthrifty loveliness, why dost thou spend
poems/Shakespeare/sonnet5:The lovely gaze where every eye doth dwell
poems/Shakespeare/sonnet9:      No love toward others in that bosom sits
/home/cis90/simben $
  
```

# grep the output of a grep

*string to search for in the output of the previous command*  
*string to search for*    *files to search contents of*  

```
[simben@opus poems]$ grep love Shakespeare/son* | grep hate
Shakespeare/sonnet10:Shall hate be fairer lodg'd then gentle love?
[simben@opus poems]$
```

*Find all lines with both love and hate*

# grep using the -n (line number) option

*string to search for*      *file to search contents of*

```
/home/cis90/simben $ grep simben90 /etc/passwd
simben90:x:1201:190:Benji Simms:/home/cis90/simben:/bin/bash
```

*Show account in /etc/passwd for simben90*

*Option to show line number*

*string to search for*      *file to search contents of*

```
/home/cis90/simben $ grep -n simben90 /etc/passwd
52:simben90:x:1201:190:Benji Simms:/home/cis90/simben:/bin/bash
```

*Found in line 52 of /etc/passwd*

*Same as before but include line number it was found on*



# grep using the -i (case insensitive) option

```
/home/cis90/simben $ grep "so" poems/Shakespeare/sonnet[345]
poems/Shakespeare/sonnet3:Thou dost beguile the world, unbless some mother.
poems/Shakespeare/sonnet3:For where is she so fair whose unear'd womb
poems/Shakespeare/sonnet3:Or who is he so fond will be the tomb,
poems/Shakespeare/sonnet5:A liquid prisoner pent in walls of glass,
```

*Look for "so" in sonnet3, sonnet4 and sonnet5*

*Use the -i option to make searches case insensitive*



```
/home/cis90/simben $ grep -i "so" poems/Shakespeare/sonnet[345]
poems/Shakespeare/sonnet3:Thou dost beguile the world, unbless some mother.
poems/Shakespeare/sonnet3:For where is she so fair whose unear'd womb
poems/Shakespeare/sonnet3:Or who is he so fond will be the tomb,
poems/Shakespeare/sonnet3:So thou through windows of thine age shalt see,
poems/Shakespeare/sonnet4:So great a sum of sums, yet canst not live?
poems/Shakespeare/sonnet5:A liquid prisoner pent in walls of glass,
```

*Look for "so" (case insensitive) in sonnet3, sonnet4 and sonnet5*

## grep using the -w (whole word) option

```
/home/cis90/simben $ grep so poems/Shakespeare/sonnet[345]  
poems/Shakespeare/sonnet3:Thou dost beguile the world, unbless some mother.  
poems/Shakespeare/sonnet3:For where is she so fair whose unear'd womb  
poems/Shakespeare/sonnet3:Or who is he so fond will be the tomb,  
poems/Shakespeare/sonnet5:A liquid prisoner pent in walls of glass,
```

*Look for "so" in sonnet3, sonnet4 and sonnet5*

*Use the -w option for whole word only searches*

```
/home/cis90/simben $ grep -w so poems/Shakespeare/sonnet[345]  
poems/Shakespeare/sonnet3:For where is she so fair whose unear'd womb  
poems/Shakespeare/sonnet3:Or who is he so fond will be the tomb,
```

*Look for "so" (whole word only) in sonnet3, sonnet4 and sonnet5*



# grep recursively with the -R option

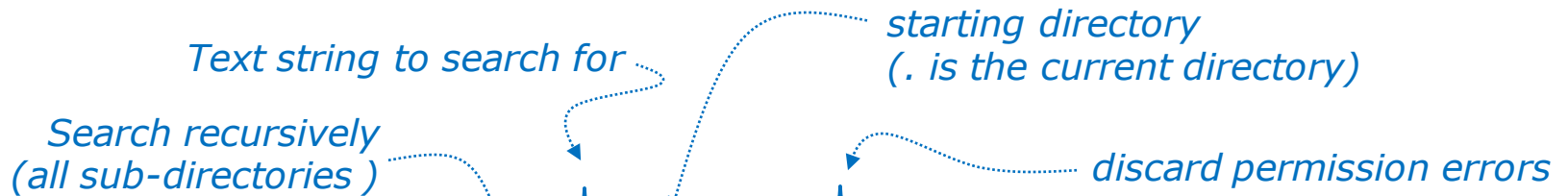

```
/home/cis90/simben $ grep -R kind . 2> /dev/null
./poems/Shakespeare/sonnet10:Be as thy presence is gracious and kind,
./poems/Shakespeare/sonnet10:Or to thyself at least kind-hearted prove:
./poems/Shakespeare/sonnet35: Let no unkind, no fair beseechers kill;
./poems/Yeats/mooncat:When two close kindred meet,
./poems/Anon/ant:distorted out of kind,
./letter:Mother, Father, kindly disregard this letter.
./bin/enlightenment: echo "to find out what kind of file \"what_am_i\" is"
./misc/mystery: echo "to find out what kind of file \"what_am_i\" is"
```

*Search recursively for files containing "kind"*

# grep command

## Background

Apache is the worlds most popular web server and it's installed on Opus. Try it, you can browse to [oslab.cabrillo.edu](http://oslab.cabrillo.edu).

Every Apache configuration file must specify the location (an absolute pathname) of the documents to publish on the world wide web. This is done with the **DocumentRoot** directive. This directive is found in every Apache configuration file.

All configuration files are kept in /etc.

## Tasks

- Can you use **grep** to find the Apache configuration file?  
*Hint: use the -R option to recursively search all sub-directories*
- What are the names of the files in Apache's document root directory on Opus?  
*Hint: Use the ls command on the document root directory*

spell  
command



# spell command

## Basic syntax

(see man page for the rest of the story)

**spell** *<filepath>*

**spell** *<filepath>* *<filepath>* ...

The **spell** command is used to check spelling of words in one or more text files

# spell command

*Task: Run a spell check on the magna\_cart file*

```
/home/cis90/simben $ cd docs  
/home/cis90/simben/docs $ ls  
magna_carta MarkTwain policy  
/home/cis90/simben/docs $ spell magna_carta  
Anjou  
Arundel  
Aymeric  
Bergh  
Daubeny  
de  
honour  
kingdon  
Pandulf  
Poitou  
Poppeley  
seneschal  
subdeacon  
Warin
```

*The spell command will  
show any words not  
found in the dictionary.*

# spell command

*Count the number of misspelled words in the magna\_carta file*

*The -l option instructs the **wc** command to just count the number of lines*

```
/home/cis90/simben/docs $ spell magna_carta | wc -l  
14
```

*Pipe the output of the **spell** command (the misspelled words) into the input of the **wc** command*

## Activity

```
/home/cis90/simben $ cat edits/spellk
```

Spell Check

```
Eye halve a spelling chequer  
It came with my pea sea  
It plainly marques four my revue  
Miss steaks eye kin knot sea.  
Eye strike a key and type a word  
And weight four it two say  
Weather eye am wrong oar write  
It shows me strait a weigh.  
As soon as a mist ache is maid  
It nose bee fore two long  
And eye can put the error rite  
Its rare lea ever wrong.  
Eye have run this poem threw it  
I am shore your pleased two no  
Its letter perfect awl the weigh  
My chequer tolled me sew.
```

```
/home/cis90/simben $
```

*How many misspelled  
word are in your spellk  
file?*

*Write your answer in the  
chat window.*



# tee command



# tee command

## Basic syntax

(see man page for the rest of the story)

**tee** *<filepath>*

The **tee** command, a filter, reads from **stdin** and writes to **stdout** AND to the file specified as the argument.

# tee command

*For example, the following command sends a sorted list of the current users logged on to the system to the screen, and saves an unsorted list to a file named users.*

```
/home/cis90/simben $ who | tee users | sort
caumar98 pts/5      2014-03-17 17:29 (75.140.158.6)
caumar98 pts/6      2014-03-17 17:41 (75.140.158.6)
chejul98 pts/1      2014-03-17 19:42 (acbe4f9e.ipt.aol.com)
goojun172 pts/7     2014-03-17 19:53 (c-67-169-144-100.hsd1.ca.comcast.net)
hovdav98 pts/2      2014-03-16 14:48 (c-76-126-1-130.hsd1.ca.comcast.net)
mmatera pts/4       2014-03-13 16:06 (2607:f380:80f:f828:e108:c48e:9e1a:57ff)
rsimms pts/0        2014-03-17 09:40 (2001:470:1f05:9b3:3044:7820:6ce0:8a4)
/home/cis90/simben $
```

```
/home/cis90/simben $ cat users
rsimms pts/0        2014-03-17 09:40 (2001:470:1f05:9b3:3044:7820:6ce0:8a4)
chejul98 pts/1      2014-03-17 19:42 (acbe4f9e.ipt.aol.com)
hovdav98 pts/2      2014-03-16 14:48 (c-76-126-1-130.hsd1.ca.comcast.net)
mmatera pts/4       2014-03-13 16:06 (2607:f380:80f:f828:e108:c48e:9e1a:57ff)
caumar98 pts/5      2014-03-17 17:29 (75.140.158.6)
caumar98 pts/6      2014-03-17 17:41 (75.140.158.6)
goojun172 pts/7     2014-03-17 19:53 (c-67-169-144-100.hsd1.ca.comcast.net)
/home/cis90/simben $
```

# tee command

```
/home/cis90/simben $ head edits/spellk
Spell Check
```

```
Eye halve a spelling chequer
It came with my pea sea
It plainly marques four my revue
Miss steaks eye kin knot sea.
Eye strike a key and type a word
And weight four it two say
Weather eye am wrong oar write
```

*The misspelled words from spell are piped to the tee command*

*The tee command copies the misspelled words to stdout and to the file named mistakes*

```
/home/cis90/simben $ spell edits/spellk | tee mistakes | wc -l
1
```

```
/home/cis90/simben $ cat mistakes
chequer
```

*The wc command counts the misspelled words*

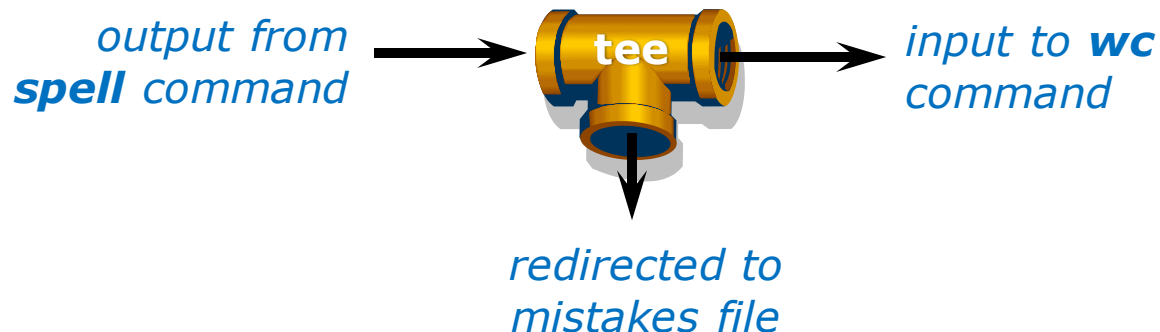



# cut command

# cut command

## Basic syntax

(see man page for the rest of the story)

**cut -f** *<num>* **-d** "*<delimiter-character>*" *<pathname>*

**cut -c** *<start column>*-*<end column>* *<pathname>*

*The **cut** command can cut text from a line by delimited fields or by a range of columns.*

# cut command

(cut text using delimited fields)

```
[rsimms@oslab ~]$ grep $LOGNAME /etc/passwd
rsimms:x:201:503:Rich Simms:/home/rsimms:/bin/bash
```

1st  
field

2nd  
field

3rd  
field

4th  
field

5th  
field

6th  
field

7th  
field

```
[rsimms@oslab ~]$ grep $LOGNAME /etc/passwd | cut -f 7 -d ":"
/bin/bash
```

Cut the 7<sup>th</sup> field

Using ":" as the delimiter

# cut command

(cut text by column numbers)

```
/home/cis90/simben $ ls -l letter
-rw-r--r--. 1 simben90 cis90 1044 Jul 20 2001 letter
123456789012345678901234567890123456789012345678901234567890
column 2 column 10
```

```
/home/cis90/simben $ ls -l letter | cut -c 2-10
rw-r--r--
```

*Cut columns  
2 through 10*

```
/home/cis90/simben $ perm=$(ls -l letter | cut -c 2-10)
This puts the output of the pipeline  
above into a variable named perm
```

```
/home/cis90/simben $ echo The permissions on letter are $perm
The permissions on letter are rw-r--r--
```

*Which we can use to  
build a custom message*



# Pipeline Practice



## Class Exercise

### Pipeline Tasks

### Background

The **last** command searches through /var/log/wtmp and prints out a list of users logged in since that file was created.

### Task

Can you see the last times you were logged in on a Wednesday and then count them?

```
last | grep $LOGNAME
```

```
last | grep $LOGNAME | grep "Wed"
```

```
last | grep $LOGNAME | grep "Wed" | wc -l
```

How many times did you log in on a Wednesday?  
Write your answer in the chat window.

## Class Exercise

### Pipeline Tasks

### Background

The **cut** command can cut a field out of a line of text where each field is delimited by some character.

The */etc/passwd* file uses the ":" as the delimiter between fields. The 5<sup>th</sup> field is a comment field for the user account.

### Task

Build up a pipeline, one pipe at a time:

```
cat /etc/passwd
```

```
cat /etc/passwd | grep $LOGNAME
```

```
cat /etc/passwd | grep $LOGNAME | cut -f 5 -d ":"
```

What gets printed with the last pipeline?  
Write your answer in the chat window.



**ONLY**  
**If Time Allows**

# Permissions

“The rest of the story”

- Special Permissions
- ACLs
- Extended Attributes
- SELinux



*This module is for your information only. We won't use this in CIS 90 but its good to know they exist. More in CIS 191, 192 and 193*



## Special Permissions

**Sticky bit** - used on directories, e.g. /tmp, so that only owners can rename or remove files even though other users may have write permission on the directory.

**SetUID or SetGID** - allows a user to run an program file with the permissions of the file's owner (Set User ID) or the file's group (Set Group ID). Examples include **ping** and **passwd** commands.



# Special Permissions

**Sticky bit** - used on directories, e.g. /tmp, so that only owners can rename or remove files even though other users may have write permission on the directory.

```
/home/cis90/simben $ ls -ld /tmp
drwxrwxrwt. 3 root root 4096 Oct 16 16:13 /tmp
```

*green background with black text*

```
/home/cis90/simben $ mkdir tempdir
/home/cis90/simben $ chmod 777 tempdir/
/home/cis90/simben $ ls -ld tempdir/
drwxrwxrwx. 2 simben90 cis90 4096 Oct 16 15:25 tempdir/
```

*green background with blue text*

```
/home/cis90/simben $ chmod 1777 tempdir
/home/cis90/simben $ ls -ld tempdir/
drwxrwxrwt. 2 simben90 cis90 4096 Oct 16 15:25 tempdir/
```

*set sticky bit*

*sticky bit set*

*green background with black text*



## Special Permissions

**SetUID or SetGID** - allows a user to run a program file with the permissions of the file's owner (Set User ID) or the file's group (Set Group ID). Examples include **ping** and **passwd** commands.

```
/home/cis90/simben $ ls -l /bin/ping /usr/bin/passwd
-rwsr-xr-x. 1 root root 36892 Jul 18 2011 /bin/ping
-rwsr-xr-x. 1 root root 25980 Feb 22 2012 /usr/bin/passwd
```

*red background  
with gray text*

```
/home/cis90/simben $ echo banner Hola > hola; chmod +x hola; ls -l hola
-rwxrwxr-x. 1 simben90 cis90 12 Oct 16 16:45 hola
```

```
/home/cis90/simben $ chmod 4775 hola
/home/cis90/simben $ ls -l hola
-rwsrwxr-x. 1 simben90 cis90 12 Oct 16 16:45 hola
/home/cis90/simben $ chmod 2775 hola
/home/cis90/simben $ ls -l hola
-rwxrwsr-x. 1 simben90 cis90 12 Oct 16 16:45 hola
```



## ACLs (Access Control Lists)

**ACLs** - offer a finer granularity of control allowing additional permissions to be set for specific users or groups.





## ACLs (Access Control Lists)

**ACLs** - offer a finer granularity of control allowing additional permissions to be set for specific users or groups.

```

/home/cis90/simben $ echo yabadabadoo > yogi
/home/cis90/simben $ chmod 400 yogi
/home/cis90/simben $ ls -l yogi
-r----- . 1 simben90 cis90 12 Oct 16 17:02 yogi

/home/cis90/simben $ getfacl yogi
# file: yogi
# owner: simben90
# group: cis90
user::r--
group:---
other:---
    
```

*Create a file and set permissions to 400*

*Use **getfacl** to show ACLs*

```

[milhom90@oslab ~]$ cat ../simben/yogi
cat: ../simben/yogi: Permission denied
    
```

*Homer, a member of the cis90 group can't read the file*

```

[rodduk90@oslab ~]$ cat ../simben/yogi
cat: ../simben/yogi: Permission denied
    
```

*Duke, a member of the cis90 group can't read the file either*



# ACLs (Access Control Lists)

*Let's give special permissions to one user*

```

/home/cis90/simben $ setfacl -m u:milhom90:rw yogi
/home/cis90/simben $ ls -l yogi
-r--rw---+ 1 simben90 cis90 12 Oct 16 17:02 yogi
/home/cis90/simben $ getfacl yogi
# file: yogi
# owner: simben90
# group: cis90
user::r--
user:milhom90:rw-
group:---
mask::rw-
other:---
    
```

*modify*

*Allow milhom90 to have read/write access*

```

[milhom90@oslab ~]$ cat ../simben/yogi
yabadabadoo
    
```

*Homer can now read the file*

```

[rodduk90@oslab ~]$ cat ../simben/yogi
cat: ../simben/yogi: Permission denied
    
```

*But not Duke*



# ACLs (Access Control Lists)

*Let's remove the special permissions to that user*

*remove all base ACLs*

```

/home/cis90/simben $ setfacl -b yogi
/home/cis90/simben $ ls -l yogi
-r-----. 1 simben90 cis90 12 Oct 16 17:02 yogi
/home/cis90/simben $ getfacl yogi
# file: yogi
# owner: simben90
# group: cis90
user::r--
group:---
other:---
    
```

*Remove all ACLs on yogi file*

```

[milhom90@oslab ~]$ cat ../simben/yogi
cat: ../simben/yogi: Permission denied
    
```

```

[rodduk90@oslab ~]$ cat ../simben/yogi
cat: ../simben/yogi: Permission denied
    
```

*Now Homer can't read it again*

*Same for Duke*



## Extended File Attributes

**Extended Attributes** - the root user can set some extended attribute bits to enhance security.

## Extended File Attributes

**FYI**  
only

*Let's use extended file attributes to totally lock down a file against changes, even by its owner!*

```
/home/cis90/simben $ echo yabadabadoo > yogi
/home/cis90/simben $ ls -l yogi
-rw-rw-r--. 1 simben90 cis90 12 Oct 16 17:29 yogi
```

*Create a sample file to work on*

*The root user sets the **immutable bit (i)** so Benji cannot remove his own file*

```
[root@oslab ~]# lsattr /home/cis90/simben/yogi
-----e- /home/cis90/simben/yogi
[root@oslab ~]# chattr +i /home/cis90/simben/yogi
[root@oslab ~]# lsattr /home/cis90/simben/yogi
----i-----e- /home/cis90/simben/yogi
```

```
/home/cis90/simben $ ls -ld ~
drwxr-xr-x. 17 simben90 cis90 4096 Oct 16 17:29 /home/cis90/simben
/home/cis90/simben $ rm yogi
rm: remove write-protected regular file `yogi'? yes
rm: cannot remove `yogi': Operation not permitted
```

!!



## Extended File Attributes

**Extended Attributes** - the root user can set some extended attribute bits to enhance security.

*The root user removes the **immutable bit (i)** so Benji can remove his own file again*

```
[root@oslab ~]# chattr -i /home/cis90/simben/yogi
[root@oslab ~]# lsattr /home/cis90/simben/yogi
-----e- /home/cis90/simben/yogi
```

```
/home/cis90/simben $ ls -ld ~
drwxr-xr-x. 17 simben90 cis90 4096 Oct 16 17:29 /home/cis90/simben
/home/cis90/simben $ rm yogi
/home/cis90/simben $
```



## Extended File Attributes

*Let's use extended file attributes to allow the file to be appended (but still not emptied or removed)*

```
/home/cis90/simben $ ls -l yogi
-rw-rw-r--. 1 simben90 cis90 12 Oct 16 17:41 yogi
```

*The root user sets the **append only bit (a)** so Benji can only append to his file*

```
[root@oslab ~]# lsattr /home/cis90/simben/yogi
-----e- /home/cis90/simben/yogi
[root@oslab ~]# chattr +a /home/cis90/simben/yogi
[root@oslab ~]# lsattr /home/cis90/simben/yogi
-----a-----e- /home/cis90/simben/yogi
```

```
/home/cis90/simben $ rm yogi
rm: cannot remove `yogi': Operation not permitted
/home/cis90/simben $ > yogi
-bash: yogi: Operation not permitted
/home/cis90/simben $ echo yowser >> yogi
/home/cis90/simben $
```



## SELinux context

**SELinux** - Security Enhanced Linux. SELinux is a set of kernel modifications that provide Mandatory Access Control (MAC). In MAC-enabled systems there is a strict set of security policies for all operations which users cannot override. The primary original developer of SELinux was the NSA (National Security Agency).





## SELinux context

*Use the Z option on the ls command to show the SELinux context on a file*

```
[root@oslab selinux]# ls -lZ test*  
-rw-r--r--. root root unconfined_u:object_r:httpd_sys_content_t:s0 test01.html  
-rw-r--r--. root root unconfined_u:object_r:httpd_sys_content_t:s0 test02.html
```

*user                  role                  type                  level*



## SELinux context

*Create two identical web pages with identical permissions*

```
[root@oslab selinux]# cp test01.html test02.html
cp: overwrite `test02.html'? yes
```

```
[root@oslab selinux]# ls -lZ test*
-rw-r--r--. root root unconfined_u:object_r:httpd_sys_content_t:s0 test01.html
-rw-r--r--. root root unconfined_u:object_r:httpd_sys_content_t:s0 test02.html
```

*Use chcon command to change the SELinux context on one file*

```
[root@oslab selinux]# chcon -v -t home_root_t test02.html
changing security context of `test02.html'
```

```
[root@oslab selinux]# ls -lZ test*
-rw-r--r--. root root unconfined_u:object_r:httpd_sys_content_t:s0 test01.html
-rw-r--r--. root root unconfined_u:object_r:home_root_t:s0 test02.html
```

*Note, the root user's home files are not appropriate web content*



# SELinux context

*SELinux won't let Apache publish a file with an inappropriate context*

```
[root@oslab selinux]# ls -lZ test*
-rw-r--r--. root root unconfined_u:object_r:httpd_sys_content_t:s0 test01.html
-rw-r--r--. root root unconfined_u:object_r:home_root_t:s0 test02.html
[root@oslab selinux]#
```

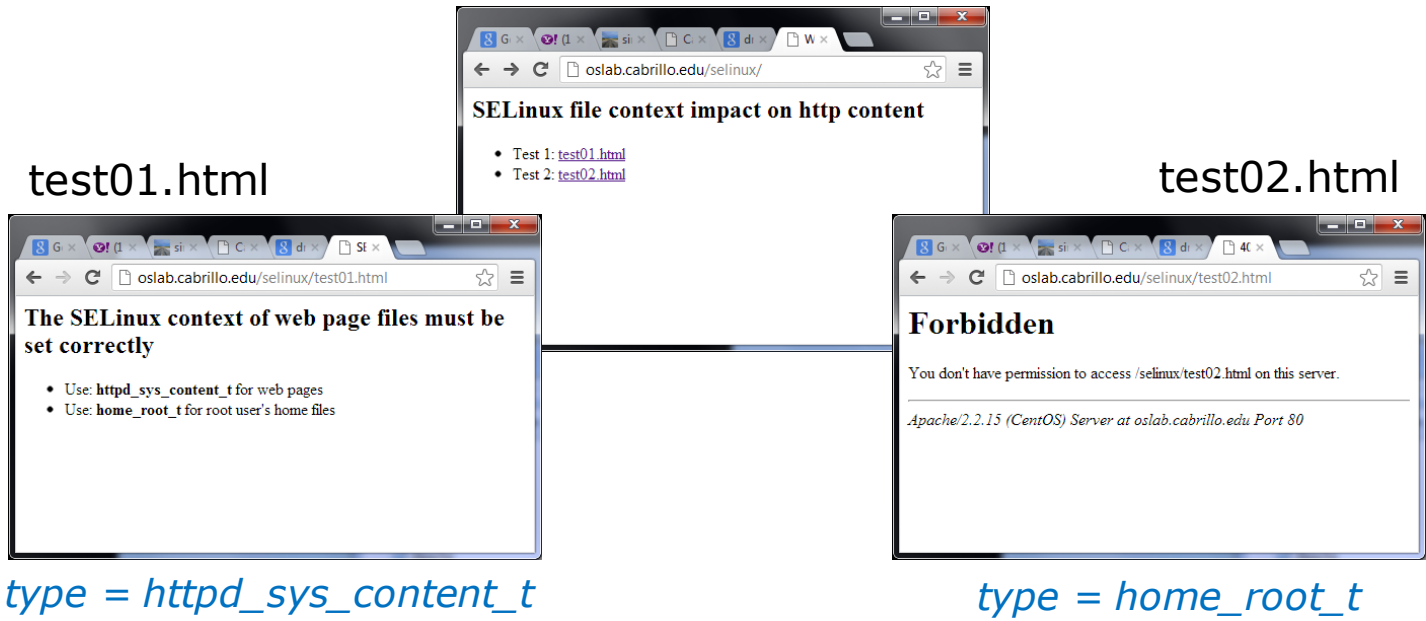



# Assignment







**Lab 7: Input and Output**

The goal of this lab is to gain proficiency in using I/O redirection to perform tasks on the system. You will combine commands you have learned in this course using shell redirection, pipes and ties to perform a variety of tasks on the system.

**Preparation:**

- Be sure to make the changes to your home directory asked for in Lab 5. This lab assumes the new names and directory structures.
- Slack Lesson 8 slides: <http://simms-teach.com/cis90calendar.php>
- Check the forum for notes on this lab: <http://oslab.cis.cabrillo.edu/forum/>
- For additional assistance come to the CIS Lab: <http://webhawks.org/~cislab/>

**Procedure:**

Log on to Open so that you have a command line shell at your service. Be sure you are in your home directory in start this lab. We are going to experiment with find commands get their input and what they do with their output. Then we will perform a series of tasks by combining commands together and saving the output to a file.

**The find command**

The syntax of the find command is:

```
find starting-directory name filename options user
```

When the *name* option and its argument are omitted all files are displayed.

- Find all the files under your home directory by issuing the command:  
`find ~`
- Find all the files owned *all* that are somewhere in or below your parent directory using the command:  
`find .. -name *`  
Were there any error messages?
- Filter out the error messages by redirecting `stderr` to a file called `errors` in your home directory:

## Lab 7

*If you get stuck please ask questions on the forum or ask the Lab Assistants in the CIS Lab.*



# Wrap up

New commands:

find

find files or content

grep

look for text strings

last

show last logins

sort

perform sorts

spell

spell checking

tee

save output to a file

wc

count lines or words in a file

## Next Class

Assignment: Check Calendar Page on web site to see what is due next week.

Lab 7

Quiz questions for next class:

- How do you redirect error messages to the bit bucket?
- What command could you use to get an approximate count of all the files on Opus and ignore the permission errors?
- For **sort dognames > dogsinorder** where does the sort process obtain the actual names of the dogs to sort?
  - a) stdin
  - b) the command line
  - c) directly from the file dognames





# Backup



# Permissions Review

# File Permissions

## Binary

*Permissions are stored internally using binary numbers and they can be specified using decimal numbers*

rwX	Binary	Convert	Decimal
- - -	0 0 0	0 + 0 + 0	0
- - x	0 0 1	0 + 0 + 1	1
- w -	0 1 0	0 + 2 + 0	2
- w x	0 1 1	0 + 2 + 1	3
r - -	1 0 0	4 + 0 + 0	4
r - x	1 0 1	4 + 0 + 1	5
r w -	1 1 0	4 + 2 + 0	6
r w x	1 1 1	4 + 2 + 1	7

r (read) is the 4's column  
w (write) is the 2's column  
x (execute) is the 1's column

# File Permissions

*An example long listing*

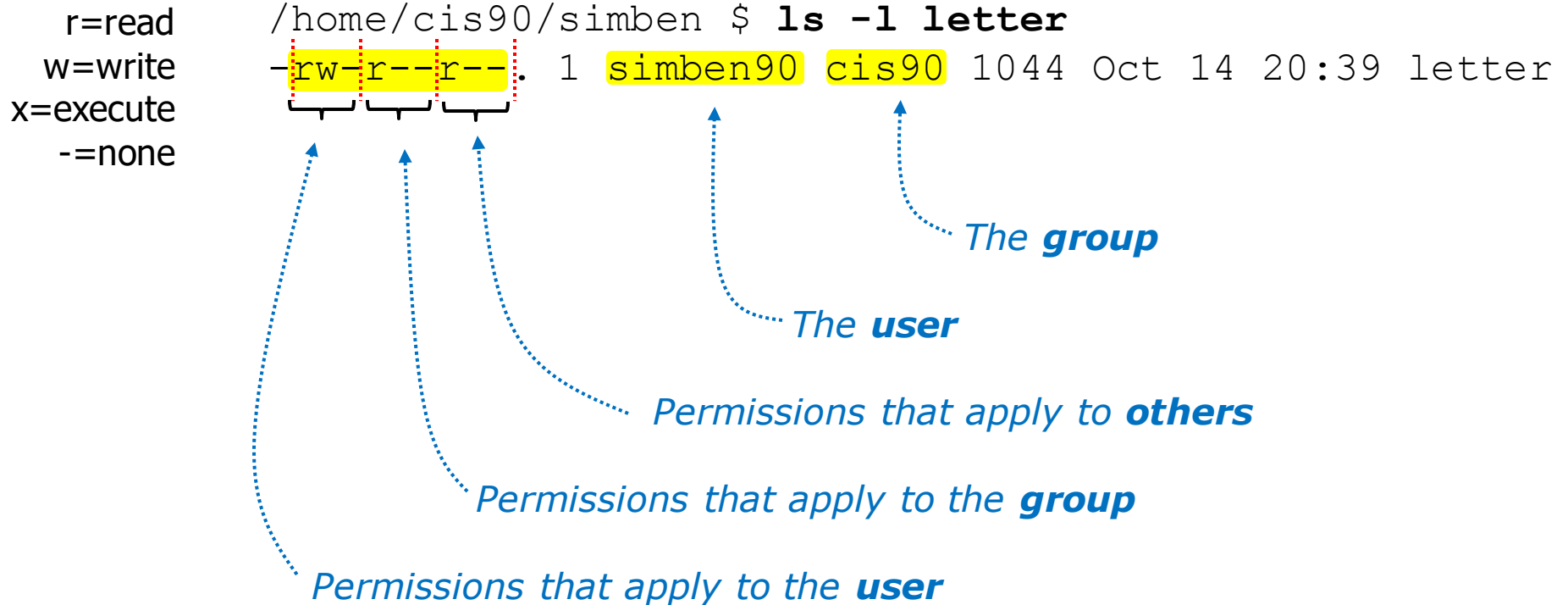

# File Permissions

```
/home/cis90/simben $ ls -l letter
-rw-r--r--. 1 simben90 cis90 1044 Oct 14 20:39 letter
```

user (owner)			group			others		
r	w	-	r	-	-	r	-	-
read	write	execute	read	write	execute	read	write	execute

The permissions on letter:  
 The **user** *simben90* has read and write permission  
 The **group** *cis90* has read permission  
 All **others** have read permission

*Use long listings to show permissions*

# File Permissions

*Use long listings to show permissions*

r=read  
 w=write  
 x=execute  
 -=none

```

/home/cis90/simben $ ls -l letter
-rw-r--r-- 1 simben90 cis90 1044 Oct 14 20:39 letter
  
```

*Permissions that apply to the **user***  
*Permissions that apply to the **group***  
*Permissions that apply to **others***  
*The **user***  
*The **group***

Does the simben90 user have execute permission on the letter file?  
*Type answer in chat window*

# File Permissions

*Use long listings to show permissions*

r=read  
 w=write  
 x=execute  
 -=none

```

/home/cis90/simben $ ls -l letter
-rw-r--r-- 1 simben90 cis90 1044 Oct 14 20:39 letter
  
```

*Permissions that apply to the **user***  
*Permissions that apply to the **group***  
*Permissions that apply to **others***  
*The **user***  
*The **group***

Does the simben90 user have execute permission on the letter file?

*No*

# File Permissions

*Use long listings to show permissions*

r=read  
 w=write  
 x=execute  
 -=none

```

/home/cis90/simben $ ls -l letter
-rw-r--r-- 1 simben90 cis90 1044 Oct 14 20:39 letter
  
```

*Permissions that apply to the **user***  
*Permissions that apply to the **group***  
*Permissions that apply to **others***  
*The **user***  
*The **group***

Does the zamhum90 user have write permission on the letter file?  
*Type answer in chat window*



# File Permissions

*Use long listings to show permissions*

r=read  
 w=write  
 x=execute  
 -=none

```

/home/cis90/simben $ ls -l letter
-rw-r--r-- 1 simben90 cis90 1044 Oct 14 20:39 letter
  
```

*Permissions that apply to the **user***  
*Permissions that apply to the **group***  
*Permissions that apply to **others***  
*The **user***  
*The **group***

Does the zamhum90 user have write permission on the letter file?

*No*

# File Permissions

*Use long listings to show permissions*

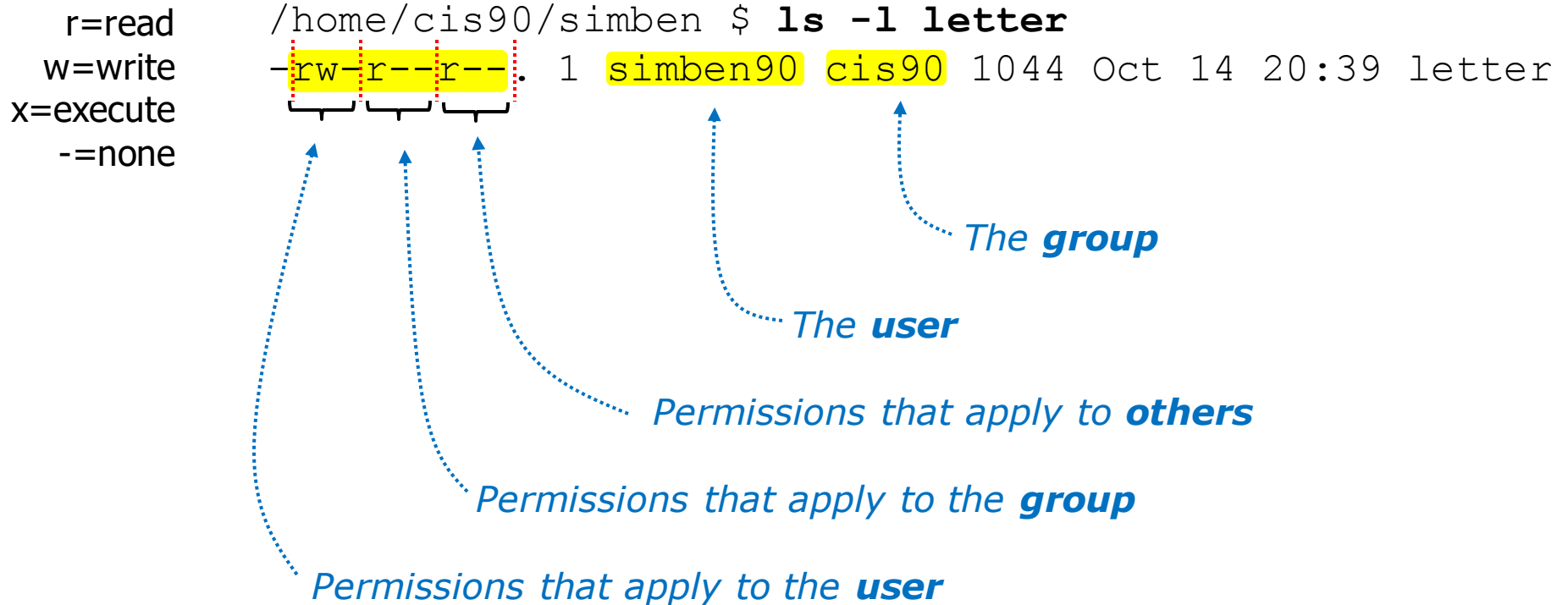

Does the zamhum90 user have read permission on the letter file?  
*Type answer in chat window*

# File Permissions

*Use long listings to show permissions*

r=read  
 w=write  
 x=execute  
 -=none

```

/home/cis90/simben $ ls -l letter
-rw-r--r-- 1 simben90 cis90 1044 Oct 14 20:39 letter
  
```

*Permissions that apply to the **user***  
*Permissions that apply to the **group***  
*Permissions that apply to **others***  
*The **user***  
*The **group***

Does the zamhum90 user have read permission on the letter file?

Yes

# File Permissions

*Use long listings to show permissions*

r=read  
 w=write  
 x=execute  
 -=none

```

/home/cis90/simben $ ls -l letter
-rw-r--r-- 1 simben90 cis90 1044 Oct 14 20:39 letter
  
```

Permissions that apply to the **user**  
 Permissions that apply to the **group**  
 Permissions that apply to **others**  
 The **user**  
 The **group**

Does the smimat172 user have read permission on the letter file?  
*Type answer in chat window*

# File Permissions

*Use long listings to show permissions*

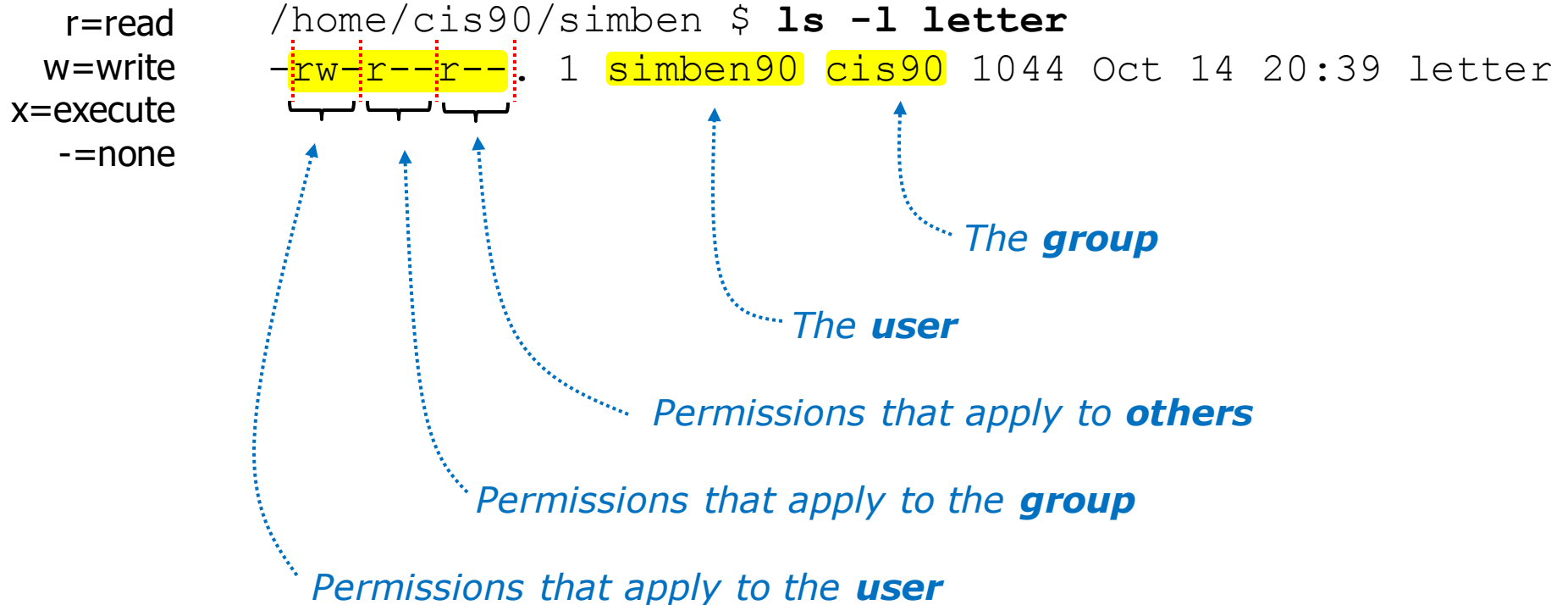

Does the smimat172 user have read permission on the letter file?

Yes



## Tools for managing permissions

**chown** - Changes the ownership of a file. (Only the superuser has this privilege)

**chgrp** - Changes the group of a file. (Only to groups that you belong to)

**chmod** - Changes the file mode “permission” bits of a file.

- Numeric: **chmod 640 letter** (sets the permissions)
- Mnemonic: **chmod ug+rw letter** (changes the permissions)  
**u**=user(owner), **g**=group, **o**=other  
**r**=read, **w**=write, **x**=execute

**umask** – Allows specific permissions to be removed on future newly created files and directories



## Tools for managing permissions

### chown

- Changes the ownership of a file. (Only the superuser has this privilege)
- Syntax: **chown <owner> <pathname>**

```
/home/cis90/simben $ ls -l letter  
-rw-r--r--. 1 simben90 cis90 1044 Oct 14 20:39 letter
```

```
/home/cis90/simben $ chown rsimms letter  
chown: changing ownership of `letter': Operation not permitted
```

*Only root (superuser) can change the ownership of a file*



## Tools for managing permissions

### chgrp

- Changes the group of a file. (Only to groups the owner belongs to)
- Syntax: **chgrp <group> <pathname>**

```
/home/cis90/simben $ ls -l letter  
-rw-r--r--. 1 simben90 cis90 1044 Oct 14 20:39 letter
```

```
/home/cis90/simben $ groups  
cis90 users
```

```
/home/cis90/simben $ chgrp users letter
```

```
/home/cis90/simben $ ls -l letter  
-rw-r--r--. 1 simben90 users 1044 Oct 14 20:39 letter
```

*The owner can change the group to any he/she belongs to*





## Tools for managing permissions

### chmod

- Changes the file mode "permission" bits of a file
- "Numeric" syntax: **chmod <numeric permission> <pathname>**

```
/home/cis90/simben $ ls -l letter
-rw-r--r--. 1 simben90 cis90 1044 Oct 14 20:39 letter
```

```
/home/cis90/simben $ chmod 750 letter
/home/cis90/simben $ ls -l letter
-rwxr-x---. 1 simben90 cis90 1044 Oct 14 20:39 letter
```

```
/home/cis90/simben $ chmod 644 letter
/home/cis90/simben $ ls -l letter
-rw-r--r--. 1 simben90 cis90 1044 Oct 14 20:39 letter
```



## Tools for managing permissions

### chmod

- Changes the file mode "permission" bits of a file.
- "Mnemonic" syntax: **chmod <u|g|o><+|-|=><r|w|x> <pathname(s)>**  
**u**=user(owner), **g**=group, **o**=other  
**r**=read, **w**=write, **x**=execute

```
/home/cis90/simben $ ls -l letter
-rw-r--r--. 1 simben90 cis90 1044 Oct 14 20:39 letter
```

```
/home/cis90/simben $ chmod u+x,g+w,o-r letter
/home/cis90/simben $ ls -l letter
-rwxrw----. 1 simben90 cis90 1044 Oct 14 20:39 letter
```

```
/home/cis90/simben $ chmod u=rw,g=r,o=r letter
/home/cis90/simben $ ls -l letter
-rw-r--r--. 1 simben90 cis90 1044 Oct 14 20:39 letter
```



## Tools for managing permissions

**umask** – Allows specific permissions to be removed on future newly created files and directories